

**KOSO** **PARCOL**

**Specialty  
Valves for  
ANTISURGE  
APPLICATIONS**







### **Basics of antisurge service**

Centrifugal compressors are widely used in all industrial plants where large volumes of gases must be handled. They are used in various sizes to handle a wide range of process fluids in a large range of flow rates, pressures and temperatures.

When compressor is running in a stable condition, with constant fluid consumption by downstream line, the specific relationship between downstream pressure and fluid flow is met by adjusting an appropriate regime of speed of compressor. When the consumption of the users varies, being not possible a fast adjustment of the speed of rotation of the compressor, a variation of the compressor downstream pressure is produced according to the characteristic curve corresponding to the current speed of rotation.

In particular, when the consumption of the users is reduced, downstream pressure increases and the working point moves to left (in diagram pressure / flow rate) approaching the line of surge with the consequent risk of cause severe damage to the compressor; in fact, in the surge area reverse flow can occur inside compressor by producing dangerous instability and strong vibrations.

To prevent this condition a control valve, named antisurge valve, is usually installed in the discharge line with appropriate instrumentation to recycle the gas to the compressor suction line. An appropriate flow through this valve ensures an adequate flow through the compressor to maintain operation above the surge point.

Surge is a very fast phenomenon that can seriously damage the compressor, therefore the safety equipments chain for the compressor protection must be very reliable and able to act in a very fast way, in order to prevent surge conditions.

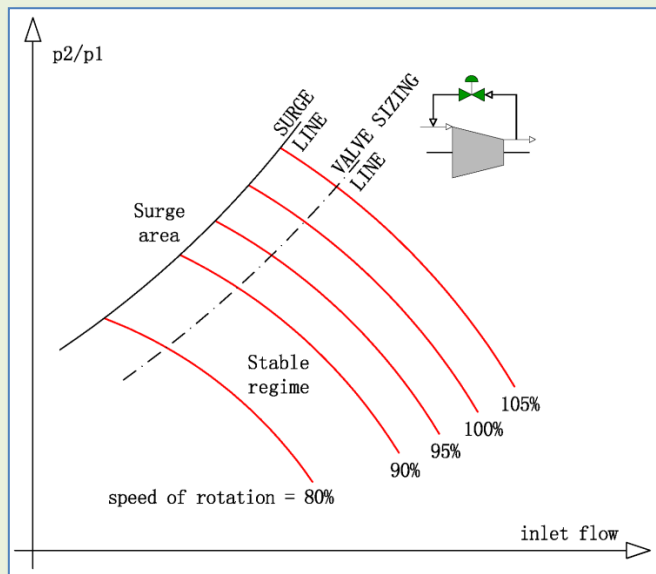

### **Valve selection criteria for antisurge service**

Generally the antisurge valves are also used during compressor startup and in any case where very low flow, lower than the compressor capability, is required. In order to allow the selected antisurge valve to handle all process conditions, its rated flow coefficient must be appropriately oversized.

Typically a 120% of oversizing is required with reference to the surge limit of 100% speed curve. Alternatively valve dimensioning can be done by applying an 80% of oversizing to surge limit of 120% speed curve.

In practice it is however recommended to agree with the compressor manufacturer the appropriate oversizing coefficient.

**PARCOL Solutions for Antisurge Service**

<b>Antisurge valve requirements</b>	<b>PARCOL Technical solutions</b>	<b>Ref.</b>
<ul style="list-style-type: none"> <li>• Fast opening</li> </ul>	⇒ Reliable and experimented actuation systems applied to the well known and reliable Parcol pneumatic actuators.	①
<ul style="list-style-type: none"> <li>• High dynamic, reduced stroking time control systems with minimized overshoot also with step set point input</li> </ul>		
<ul style="list-style-type: none"> <li>• Precise and repeatable flow control capability</li> </ul>	⇒ Thanks to the consolidated experience in control valves, Parcol can ensure a precise and repeatable control function even for the most critical applications.	②
<ul style="list-style-type: none"> <li>• Reduced vibrations</li> </ul>	⇒ Process fluid velocity control with Parcol multi stages or Limiphon trims.	③
<ul style="list-style-type: none"> <li>• Valve lifetime maximization</li> </ul>	⇒ ITS design to exclude sealing surface damage during flow control.	④
	⇒ CCF design to minimize throttling area erosion during flow control.	⑤
	⇒ Practically no trim erosion trough process fluid velocity control inside Limiphon trim.	③
<ul style="list-style-type: none"> <li>• Low noise generation in all working conditions</li> </ul>	⇒ Low noise or Limiphon trims allows to reduce produced aerodynamic noise without practical limitations.	③
<ul style="list-style-type: none"> <li>• High reliability (very high MTBF)</li> </ul>	⇒ Parcol experience on heavy duty control valves (SIL 3).	⑥
	⇒ Low emission packings equipped with proprietary live-loading system to increase reliability and Time To Maintenance (TTM).	⑦
<ul style="list-style-type: none"> <li>• Reduced MTTR</li> </ul>	⇒ All Parcol valves for antisurge service are supplied equipped with quick change trim.	⑧
<ul style="list-style-type: none"> <li>• Reduced and reliable seat leakage in closed position (Class V to VI)</li> </ul>	⇒ ITS design.	④
	⇒ Proven and reliable systems for valve plug balancing seal: thanks to a wide range of seal inserts for balanced plug, Parcol control valves can comply with most stringent seat leakage classes, warranting class VI up to 280°C and class V up to 600 °C and over.	⑨
<ul style="list-style-type: none"> <li>• Good and precise control at low flow regimes</li> </ul>	⇒ Modified linear flow characteristic or tailor-made flow characteristic.	②

**1** Step response 5% to 95% of a 330 mm stroke control valve actuated through a pneumatic cylinder equipped with high dynamic electro pneumatic components.

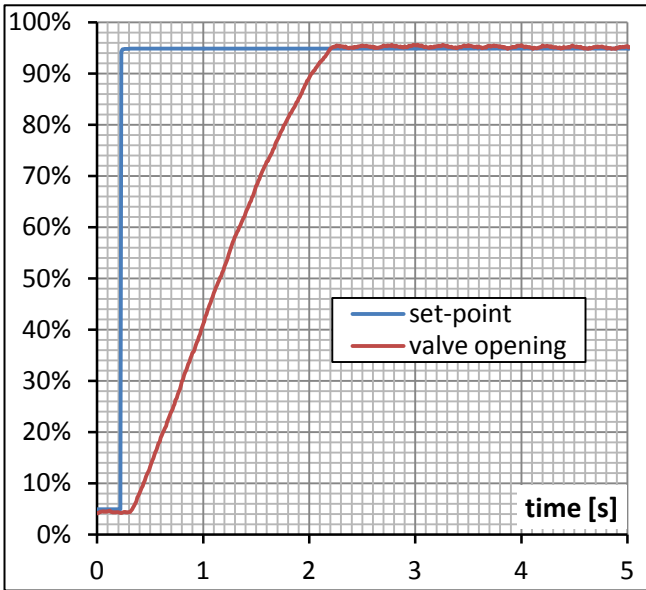

**2** Multi-path, multi-step low noise Limiphon trim combined with a high capacity single cage trim to withstand critical working service conditions by warrant high flow capacity.

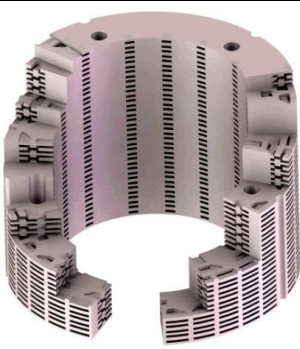
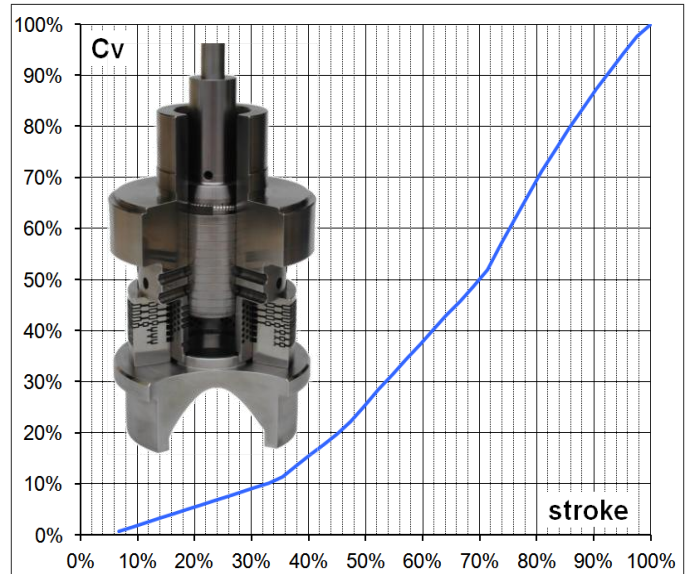

**3** Limiphon trim allows a precise control of fluid velocity inside the valve trim reducing vibrations and noise for practically any process condition.

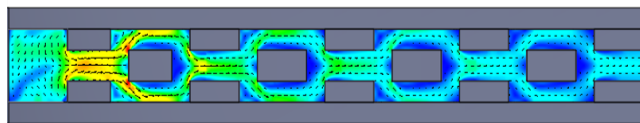

**4** ITS, Independent Throttling and Sealing system, working principle.

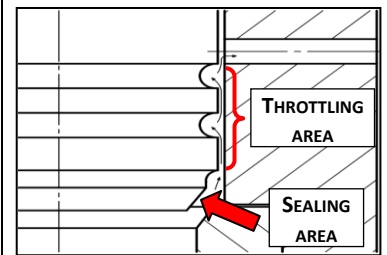

**5** CCF, Cascade Clearance Flow, working principle allows to split pressure drop in the clearance area.

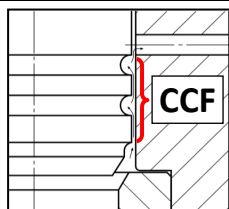

**6** Parcol control valves reliability is supported by SIL3 certification.

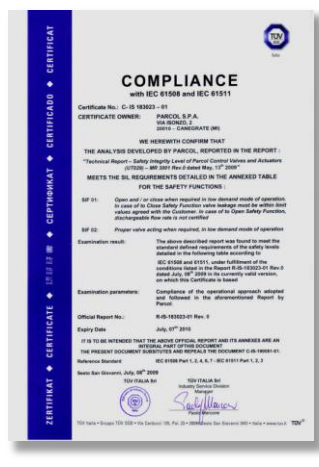

**7** Parcol low emission certified packing are all equipped with live loading spring system and sand protection in order to increase maximize Time To Maintenance and valve reliability.

**8** Thanks to the special free expanding design solution, with internal spring, all valves can be supplied with quick change trim without practical temperature limits.

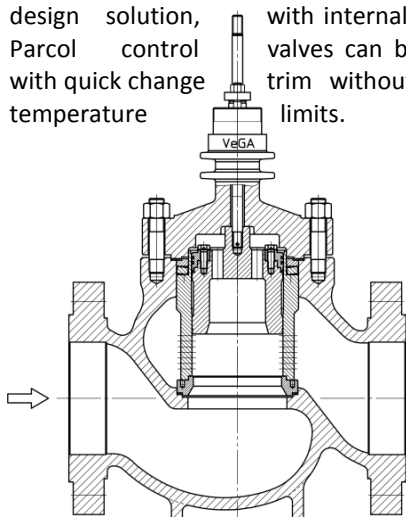

**9** Parcol balanced plug with double, static/dynamic, seal with Inconel C-Ring seal ring, can comply with IEC 60534-4 leakage class V without any temperature limitation.

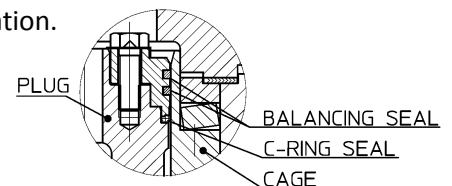

Loaded PTFE self energizing seal ring for applications up to IEC 60534-4 class.

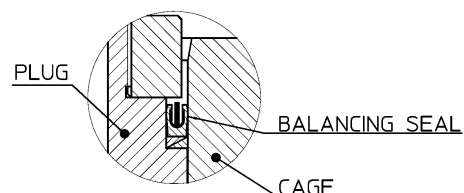

### ***PARCOL Antisurge Valves Main features***

- Cast or forged, straight way or angle valve body shape, according to process conditions and customer requirements.
- Range of sizes: up to DN 48”.
- Ratings: up to ANSI 4500.
- Operating temperature range: -55 °C to 620 °C, -196 °C for cryogenic service with special execution.
- Quick change design up to maximum allowed working temperature.
- High flow capacity thanks to the optimized shape of the valve body and to special designed of valve trim solutions.
- High Rangeability and reduced clearance wear thanks to **CCF (Cascade Clearance Flow)** plug design.
- High reliable sealing function due to **ITS (Independent Throttling and Seating)** plug design.
- Sealing class V IEC 60534-4 for all working temperatures with metallic C-ring seal.  
Sealing class VI IEC 60534-4 on request up to 280 °C.
- Single or double cage, Limiphon multipath-multistage trim or combined Limiphon/cage trim.
- Low emissions certified packings equipped with live loading system.
- Fast opening and precise and stable control, thanks to an appropriate actuator and instrumentation selection, based on many years of experience on severe service applications.





