

APPLICATIONS - VALVE SOFT SEAT/SEAL MATERIALS

One of the most important factors affecting shutoff capability is the nature of media being handled. Service life is affected by all of the following factors: - pressure, temperature, degree of pressure fluctuation and thermal fluctuation, type of media, cycling frequency, velocity of media & speed of valve operation.

The following seat & seal materials can be used in various valves such as ball, plug, butterfly, needle, etc.

BUNA-N (HYCAR or Nitrile) - Buna-N is a general-purpose polymer which has good resistance to oil, water, solvents and hydraulic fluids. It also displays good compression, abrasion resistance, and tensile strength. This material performs extremely well in process areas where paraffin base materials, fatty acids, oils, alcohols or glycerins are present, since it is totally unaffected. It should not be used around high polar solvents (acetones, ketones), chlorinated hydrocarbons, ozone or nitro hydrocarbons. Temperature range is 107°C maximum. Hycar is black in colour and should not be used where discolouration cannot be tolerated. It is regarded as a comparable replacement neoprene. Major differences are: Buna-N has a higher temperature limit; neoprene is more resistant to oils.

EPDM - EPDM is a terpolymer elastomer made from ethylene-propylene diene monomer. EPDM has good abrasion and tear resistance and offers excellent chemical resistance to a variety of acids and alkalines. It is susceptible to attacks by oils and is not recommended for applications involving petroleum oils, strong acids, or strong alkalines. EPDM should not be used on compressed air lines. It has exceptionally good weather aging and ozone resistance. Temperature rating is from -29°C to 107°C (121°C intermittent service). It is fairly good for ketones and alcohols.

HYPALON® - Hypalon has very good resistance to oxidation, ozone and good flame resistance. It is similar to neoprene except with improved acid resistance where it will resist such oxidizing acids as nitric, hydrofluoric and sulfuric acid. Abrasion resistance of Hypalon is excellent, about the equivalent of the nitriles. Oil and solvent resistance is somewhat between that of neoprene and nitriles. Salts have little if any effect on Hypalon. Hypalon is not recommended for exposure to concentrated oxidizing acids, esters, ketones, chlorinated, aromatic and nitro hydrocarbons. Not to be used in steam service. Temperature rating is from -18°C to 104°C. Seats are white food grade and may be used on food service as well as bleached paper lines.

NEOPRENE - Neoprene is an all-purpose polymer with many desirable characteristics. Neoprene features high resiliency with low compression set flame resistance and animal and vegetable oil resistance. It is principally recommended for use in pulp and paper applications. Generally, neoprene is not recommended and is attacked by strong oxidizing acids, most chlorinated solvents, esters, ketones, aromatic hydrocarbons and hydraulic fluids. Neoprene is not generally affected by moderate chemicals, fat, greases and many oils and solvents. Temperature rating is from -29°C to 82°C. Seats are black in colour and should not be used on bleached paper lines.

PTFE (TFE of Teflon®) - PTFE is the most chemically resistant of all plastics. It also has excellent thermal and electrical insulation properties. PTFE's mechanical properties are low compared to other engineering plastics, but its properties remain at useful levels over a great temperature range (-100°C to 204°C, depending on brand and application).

RTFE (Reinforced TFE) - RTFE is compounded with a selected percentage of fibre glass filler to improve strength and resistance to abrasive wear, cold flow, and permeation in molded seats. Reinforcement permits application at higher pressure and temperature than unfilled TFE. Typical temperature range is -60°C to 232°C. RTFE should not be used in applications that attack glass, such as hydrofluoric acid and hot strong caustics.

CARBON FILLED TFE - Carbon filled TFE is an excellent seat material for steam applications as well as high efficiency oil-based thermal fluids. Fillers including graphite enable this seat material to have a better cycle life than other filled or reinforced TFE seats. Temperature range is -50°C to 260°C. Chemical resistance is equal to other TFE seats.

TFM1600 - TFM1600 is a modified version of PTFE that maintains the exceptional chemical and heat resistance properties of PTFE, but has a significantly lower melt viscosity. The result is reduced cold flow, porosity, permeability and void content. Surfaces are smoother and reduce torques. The theoretical service range for TFM1600 is -200°C to 260°C.

TFM1600+20%GF - TFM1600+20%GF is a fibre glass reinforced version of TFM1600. Similar to RTFE, but with the benefit of TFM1600, the glass filled version provides greater abrasion resistance and improves stability at higher pressures.

TFM4215 - TFM4215 is an elector graphitized carbon filled TFM material. The added carbon improves stability for higher pressure and temperature combinations.

VITON® (Fluorocarbon, FKM, or FPM) - Fluorocarbon elastomers are inherently compatible with a broad spectrum of chemicals. Because of this extensive chemical compatibility which spans considerable concentration and temperature ranges, fluorocarbon elastomers have gained wide acceptance as a material of construction for knife gate valve seats.

Fluorocarbon can be used in most applications involving mineral acids, salt solutions, chlorinated hydrocarbons and petroleum oils. It is particularly good in hydrocarbon service. Temperature rating is from -29°C to 149°C. Colour is grey (black) or red and may be used on bleached paper lines. Fluorocarbon (VITON) is not suitable for steam or hot water service, however, in o-ring form it can be acceptable for hydrocarbon lines mixed with hot water depending on the type/brand. For seat materials FKM can offer more resistance to hot water - consult manufacturer.

PEEK - Polyetheretherketone - high pressure semi-rigid elastomer. Best suited for high pressure and temperature service. Also offers very good corrosion resistance. Temperature rating -56.6°C to 288°C.

DELRIN/POM - Special Delrin seats offered for higher pressure and lower temperature service. Can be used in high pressure air, oil and other gas media but are not suited for strong oxidizing. Temperature rating -50°C to 100°C.

NYLON/DEVLON - Nylon (polyamide) seats are offered for higher pressure and lower temperature service. They can be used in high temperature air, oil and other gas media but are not suited for strong oxidizing. Not recommended for water. Temperature rating -100°C to 150°C.

KELF - Recommended for cold service with good resistance to violent temperature fluctuations. It is good for cryogenic service down to -198°C and has a higher deformation rating and density than PTFE.

UHMW POLYETHYLENE - Ultra-high molecular weight Polyethylene, ideal for use in low level radiation service. This seat also meets the requirements of the tobacco industry where TFE is prohibited and it offers excellent resistance to abrasive media. Temperature range -56.6°C to 93°C.

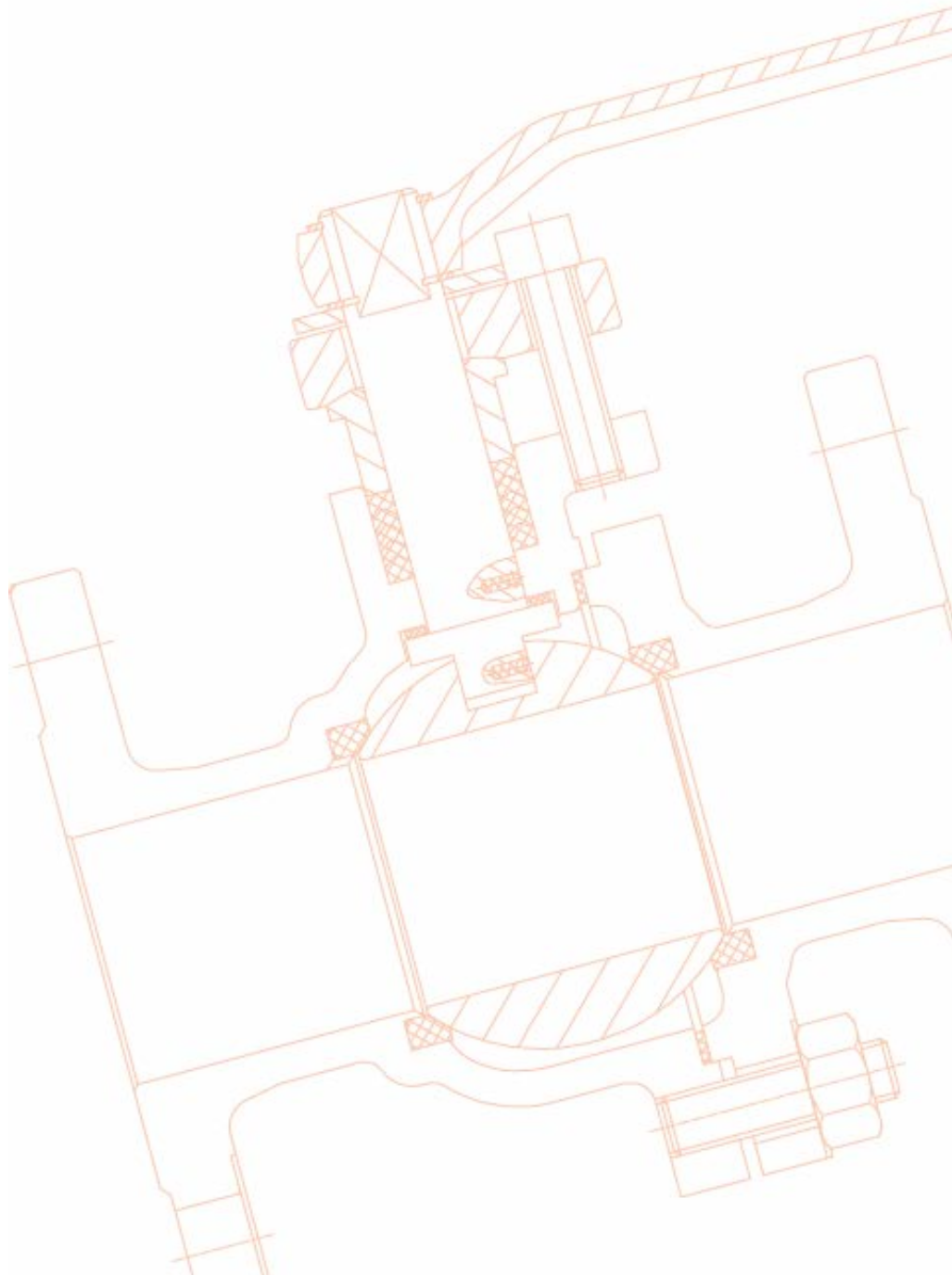

BALL VALVE SEAT/SEAL SELECTION GUIDE

STANDARD BALL VALVE SEAT SELECTIONS

Material	Technical Description	Typical Colour	Approx. Torque Adder
DELRIN/ POM	Delrin® is one trade name for POM. Competitors just market it as POM. This seat is very rigid and does not undergo cold flow. Delrin can withstand pressures of up to 6000 psi dependent on valve size and temperature range of -57°C to 82°C. Delrin/POM also withstands nuclear radiation at doses of up to 106 rads. Delrin/POM has low water absorption. Do not use on oxygen service, or steam. Different brands may vary the PTFE filled percentage providing wider temperature & service range and a superior seal.		+50%
TFM	TFM offers all of the properties of reinforced TFE with greater strength, toughness, and improved thermo mechanical properties offering lower coefficient of friction for lower torques and less permeability, reduced cold flow deformation and enhanced deformation recovery. Temperature range -45°C to 260°C.	Off-White	10% Less than RPTFE
Kel F (PCTFE)	This material is a fluorocarbon rubber. Kel F is a registered trademark of 3M Corp. It can be used for cryogenic service at temperatures of -240°C to 260°C at pressures up to 15000 psi.		+45%
Metal to Metal	Recommended for service with severe flashing or hydraulic shock, abrasive media or where possible trapped metal may exist. APV's metal seats are hand lapped to the ball as individually matched sets, assuring line contact between valve ball and seats, resulting in smooth operation and tight shut off class. APV offers metal seats in different classes of Shut Off including Class I, V and VI.	Metallic	+50%
Nylon	Special Nylon seats are offered for higher pressure and lower temperature service. They can be used in high-pressure air, oil and other gas media but are not suited for strong oxidising agents. Temperature rating -34°C to 93°C.	Translucent White	+35%
PEEK	This material offers a unique combination of chemical mechanical electrical and thermal properties. The only known solvent of Peek is concentrated sulfuric acid. It will withstand temperatures up to 316°C and pressures up to 6000 psi.	Brown	+50%
Reinforced TFE	This is produced by adding at least 15% fibrous glass to Virgin Teflon and has a greater pressure temperature rating than Teflon. RPTFE also has a better cycle life than Teflon.	Off-White	Standards as indicated in literature
Metal PTFE	Metal PTFE seats provide the combined strength of metal with the lubricity of TFE. These seats are 50% 316 powder combined with 50% TFE. Offers the abrasion resistance of metal with higher pressure and temperature ratings than RPTFE. Temperature rating -29°C to 288°C/ Steam rating 250 SWP.	Grey	+50%
Virgin TFE	This is the most widely used seating material and is excellent for most services. It has excellent chemical resistance throughout valve industries and low coefficient of friction. Temperature range -45°C to 232°C.	Opaque White	Standards as indicated in literature
UHMW Polyethylene	UHMW polyethylene is used for highly radioactive materials where TFE is not acceptable (> 104 rads) and is rated 2 x 107 rads. These seats also meet the requirements of the tobacco industry whenever TFE is prohibited, and are especially well-suited for handling highly abrasive media. Temperature range -57°C to 93°C, not suitable for steam.	Off-White	+35%
Carbon PTFE	This is a Teflon base filled with carbon powder and graphite. It has a lower thermal contraction-expansion rate than PTFE and is ideal for steam or thermal fluid applications up to 302°C.	Black	+50%

BALL VALVE SEAT GUIDE FOR STEAM USE

Service Pressure	Corresponding Saturated Steam Temperature	Seat	Stem Seal	Body Seal
Pressure Steam up to 150 psi	Maximum 186°C	PTFE or TFM	TFM	Graphite
Pressure Steam up to 170 psi	Maximum 191°C	RPTFE	Graphite	Graphite
Pressure Steam up to 250 psi	Maximum 208°C	Carbon PTFE or Metal PTFE	Graphite	Graphite
Pressure Steam up to 300 psi	Maximum 217°C	Peek	Graphite	Graphite
Pressure Steam above 300 psi	Higher than 217°C	Metal	Graphite	Graphite

BALL VALVE SEAT/SEAL SELECTION GUIDE

STANDARD BALL VALVE SEAL SELECTIONS

Material	Technical Description	Colour
GRAPHOIL	Useable from -57°C to 538°C on almost any media. It is the standard seal on all fire rated valves.	Black
Reinforced TFE	This is produced by adding 15% fibrous glass to Virgin Teflon and has a greater pressure temperature rating than Teflon. They also have a better cycle life than Teflon.	Off-White
Stainless Filled TFE	Combined the strength of metal with the lubricity of TFE. 50% 316 powder combined with 50% TFE. Offers the abrasion resistance of metal with higher pressure and temperature ratings than RPTFE. Temperature rating -29°C to 288°C/ Steam rating 250 SWP.	Grey
Virgin TFE	Teflon is excellent at pressure below 1500 psi & at temperatures from -29°C to 204°C. It will not withstand temperature fluctuations in excess of 93°C & are not reusable. It has excellent resistance to a wide range of chemicals.	White
UHMW Polyethylene	This is rated to 1500 psi at temperatures from -57°C to 93°C. This can be used in low to medium level radiation service and in applications where fluorocarbons can not be tolerated. Abrasion resistance is quite good.	Opaque White
Viton	These body seals are excellent at all rated pressures with a temperature range of -29°C to 204°C. Viton is the best elastomer seal for higher temperature applications, but it should not be used on steam. There are numerous grades of viton available including Anti Explosive Decompression (A.E.D)	Black
Spiral Wound Wire Graphite	Manufactured by spirally winding a performed V shape SS316 metal strip and a graphite sealing filler in combination. This gasket has adequate flexibility and recovery to maintain a seal under variable and uneven loading, pressure, temperature fluctuation, bolt stress, relaxation and creep. Temperature range from 160°C to 538°C.	Black

Pressure Relieving & Equalising Seat Design



Specially designed APV seats allow equalisation of pressure in the ball cavity which reduces operating torque and increases seat life.

Seat Pressure Temperature Chart

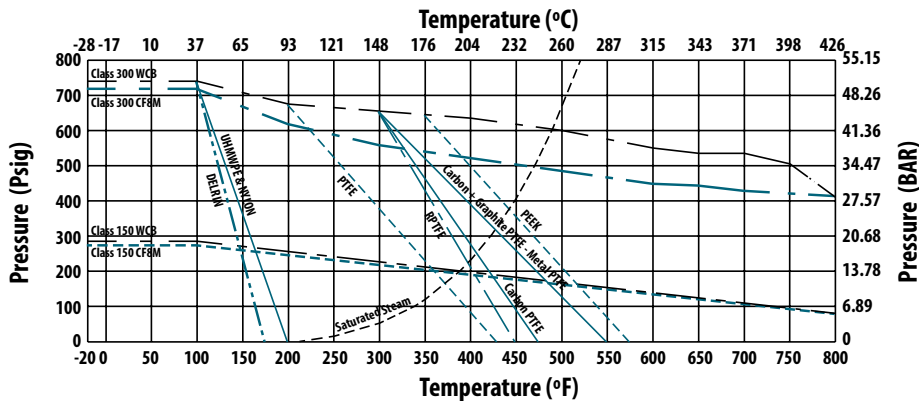

~ SHORT LEAD TIME VALVE MANUFACTURER ~

© Copyright Australian Pipeline Valve 2021