

**ASME B16.34-1996**  
(Revision of ASME/ANSI B16.34-1988)

# **VALVES—FLANGED, THREADED, AND WELDING END**

**AN AMERICAN NATIONAL STANDARD**



The American Society of  
Mechanical Engineers



The American Society of  
Mechanical Engineers

A N A M E R I C A N N A T I O N A L S T A N D A R D

# VALVES—FLANGED, THREADED, AND WELDING END

**ASME B16.34-1996**  
(Revision of ASME/ANSI B16.34-1988)

AN AMERICAN NATIONAL STANDARD

# **ASME B16.34a-1998**

## **ADDENDA**

to

ASME B16.34-1996  
VALVES — FLANGED, THREADED,  
AND WELDING END

THE AMERICAN SOCIETY OF MECHANICAL ENGINEERS

Three Park Avenue • New York, NY 10016

Date of Issuance: November 2, 1998

ASME is the registered trademark of The American Society of Mechanical Engineers.

This code or standard was developed under procedures accredited as meeting the criteria for American National Standards. The Standards Committee that approved the code or standard was balanced to assure that individuals from competent and concerned interests have had an opportunity to participate. The proposed code or standard was made available for public review and comment which provides an opportunity for additional public input from industry, academia, regulatory agencies, and the public-at-large.

ASME does not "approve," "rate," or "endorse" any item, construction, proprietary device, or activity.

ASME does not take any position with respect to the validity of any patent rights asserted in connection with any items mentioned in this document, and does not undertake to insure anyone utilizing a standard against liability for infringement of any applicable Letters Patent, nor assumes any such liability. Users of a code or standard are expressly advised that determination of the validity of any such patent rights, and the risk of infringement of such rights, is entirely their own responsibility.

Participation by federal agency representative(s) or person(s) affiliated with industry is not to be interpreted as government or industry endorsement of this code or standard.

ASME accepts responsibility for only those interpretations issued in accordance with governing ASME procedures and policies which preclude the issuance of interpretations by individual volunteers.

No part of this document may be reproduced in any form,  
in an electronic retrieval system or otherwise,  
without the prior written permission of the publisher.

The American Society of Mechanical Engineers  
Three Park Avenue, New York, NY 10016-5990

Copyright © 1998 by  
THE AMERICAN SOCIETY OF MECHANICAL ENGINEERS  
All Rights Reserved  
Printed in U.S.A.

**ASME B16.34a-1998**

Following approval by the ASME B16 Committee and ASME, and after public review, ASME B16.34a-1998 was approved by the American National Standards Institute on April 3, 1998.

Addenda to the 1996 Edition of ASME B16.34 are issued in the form of replacement pages. Revisions, additions, and deletions are incorporated directly into the affected pages. It is advisable, however, that this page, the Addenda title and copyright pages, and all replaced pages be retained for reference.

**SUMMARY OF CHANGES**

This is the first Addenda to be published to ASME B16.34-1996.

Replace or insert the pages listed. Changes given below are identified on the pages by a margin note, (a), placed next to the affected area. The pages not listed are the reverse sides of the listed pages and contain no changes.

<i>Page</i>	<i>Location</i>	<i>Change</i>
vi	Foreword	In the last paragraph, ASME address updated
vii, viii	Committee Roster	Updated
2	2.1(g)	Second line corrected by Errata
5	5.1.2	Fourth line corrected by Errata
7	6.2.1	Subparagraphs (a), (b), and (c) corrected by Errata
10	6.7	(1) Title corrected by Errata (2) Subparagraph (g) deleted
	7.1	In first paragraph, eighth line corrected by Errata
22	Fig. 17	Revised
23-28	Table 1	(1) In Group No. 1.1, Nominal Designation and Forgings revised (2) In Group No. 1.2, Nominal Designation and Forgings revised (3) Group No. 1.15 added (4) In Group No. 2.2, under Nominal Designation, <i>16Cr-2Ni-2Mo</i> corrected by Errata to read <i>16Cr-12Ni-2Mo</i> (5) Group No. 2.8 revised

(c)

<i>Page</i>	<i>Location</i>	<i>Change</i>
23-28	Table 1	(6) In Group No. 3.1, Nominal Designation and Castings revised (7) In Group No. 3.8, Forgings, Spec. No. B 574 corrected by Errata to read B 564 (8) Group No. 3.17 added
33	Table 2-1.1	(1) Third column revised (2) Note (7) added
34	Table 2-1.2	(1) Revised (2) Note (4) added
36	Table 2-1.4B	Working pressure for Class 4500 at 600°F corrected by Errata to read 8,920
37	Table 2-1.5	First line of Note (1) corrected by Errata
	Table 2-1.5B	Working pressure for Class 900 at 950°F corrected by Errata to read 1,055
38	Table 2-1.6	Note (1) corrected by Errata
52	Table 2-1.14B	Working pressure for Class 1500 at 700°F corrected by Errata to read 3,665
52.1	Table 2-1.15	Added
	Table 2-1.15A	Added
	Table 2-1.15B	Added
53	Table 2-2.1A	Working pressure for Class 300 at 1050°F (310) added by Errata
54	Table 2-2.1B	(1) Working pressure for Class 600 at 200°F corrected by Errata to read 1,335 (2) Working pressure for Class 900 at 1050°F corrected by Errata to read 1,155
55, 56	Table 2-2.2	(1) In second column, A 351 Gr. CF3H corrected by Errata to read A 351 Gr. CF3M (2) In third column, A 351 Gr. CF8H corrected by Errata to read A 351 Gr. CF8M (3) In fourth column, A 351 Gr. CG8H corrected by Errata to read A 351 Gr. CG8M
	Table 2-2.2B	Working pressure for Class 900 at 1450°F corrected by Errata to read 220
57	Table 2-2.3B	(1) Working pressure for Class 600 at 850°F corrected by Errata to read 720 (2) Working pressure for Class 900 at 800°F corrected by Errata to read 1,100
58	Table 2-2.4A	Under Working Pressure for Class 600: (1) At 1150°F, 370 corrected by Errata to read 475

(d)

<i>Page</i>	<i>Location</i>	<i>Change</i>
58	Table 2-2.4A	(2) At 1200°F, 365 corrected by Errata to read 370
66	Table 2-2.8	(1) New second column added (2) A 351 Gr. CE8MN, A 351 Gr. CD4MCu, and A 351 Gr. CD3MWCuN added to fourth column
67	Table 2-3.1	Revised
	Table 2-3.1A	Revised in its entirety
	Table 2-3.1B	Revised in its entirety
70	Table 2-3.3B	Working pressure for Class 600 at 700°F corrected by Errata to read 480
72	Table 2-3.5A	Working pressure for Class 4500 at 1150°F corrected by Errata to read 1,020
75	Table 2-3.7B	Working pressure for Class 1500 at 700°F corrected by Errata to read 3,665
79	Table 2-3.9B	Working pressure for Class 1500 at 400°F corrected by Errata to read 3,335
81	Table 2-3.11B	Working pressure for Class 150 at 700°F corrected by Errata to read 175
86	Table 2-3.15B	Working pressure for Class 2500 at 1250°F corrected by Errata 1,895
87	Table 2-3.16A	Working pressure for Class 2500 at 1150°F corrected by Errata to read 1,545
88.1	Table 2-3.17	Added
	Table 2-3.17A	Added
	Table 2-3.17B	Added
92	Table 4	Column head <i>50 Through 300</i> corrected to read <i>150 Through 300</i> by Errata
93	Annex A	In second paragraph, eleventh line corrected by Errata
103–105	F2.1	(1) In nomenclature, $P_{ca}$ corrected to read $p_{ca}$ by Errata (2) In subparagraph (d), first line corrected by Errata
	F3.1	(1) In nomenclature, $P_{sp}$ corrected to read $p_{sp}$ by Errata (2) In nomenclature, $P_{cb}$ corrected to read $p_{cb}$ by Errata
106	Table F4-A	Title, <i>Special Class Valves</i> , corrected by Errata to read <i>Standard Class Valves</i>

(e)

<i>Page</i>	<i>Location</i>	<i>Change</i>
109	G2.1.3	(1) In nomenclature, $P_{ld}$ corrected by Errata to read $p_{ld}$
109	G2.1.3	(2) In nomenclature, $P_{sp}$ corrected by Errata to read $p_{sp}$
		(3) Text table head <i>900 and Above</i> corrected by Errata to read <i>900 and Below</i>
110	G6.1.8	In nomenclature, $P_o$ corrected by Errata to read $p_o$
115	Annex I	ASME address updated
119	Interpretations	ASME address updated

**SPECIAL NOTE:**

The Interpretations to ASME B16.34 are included in this Addenda as a separate section for user's convenience. This section, however, is not part of the Addenda or the edition.



## INTRODUCTORY NOTES

(These introductory notes are not part of ASME B16.34-1996.)

An American National Standard is intended as a basis for common practice by the manufacturer, the user, and the general public. The existence of an American National Standard does not in itself preclude the manufacture, sale, or use of products not conforming to the standard. Mandatory conformance is established only by reference to the standard in a code, specification, sales contract, or public law.

It should be noted, specifically with regard to *this* Standard, that certain requirements reflecting the *general* application of valves in a wide variety of services may not be considered to be appropriate for some valves whose application is known and which may incorporate certain features found by successful experience to be satisfactory. A specific case in point is that involving valves developed and used in gas and petroleum product pipelines. Conformance of such valves to the existing industry standard, API 6D, may by itself be sufficient to satisfy the requirements of Federal Rules and Regulations established by the Department of Transportation, Office of Pipeline Safety Operations. Another specific case is that involving valves used in instrument systems under an applicable Piping Code. Conformance of such valves to the requirements of an existing Piping Code may by itself be sufficient to satisfy jurisdictional rules and regulations.

This edition of ASME B16.34 is based on U.S. Customary Units of measurement which are to be regarded as the standard. Conversion factors between metric SI units and U.S. Customary Units are given in SI-1, ASME Orientation and Guide for Use of SI (Metric) Units, and ASTM E380. Care is required when converting equations that contain constant terms or factors since they may also require conversion.

**FOREWORD****(a)**

(This Foreword is not part of ASME B16.34-1996.)

In December 1969, American National Standards Committee B16 changed its name from Standardization of Pipe Flanges and Fittings to Standardization of Valves, Fittings, and Gaskets, reflecting American National Standards Institute approval of a broadened scope for the B16 Committee. At the same meeting, the committee approved a plan for the organization of a subcommittee to develop a new standard for steel valves with other than flanged ends. Subsequently, B16 Subcommittee 15 was appointed and held its first meeting in December 1970.

Historically, in the development of standards and pressure-temperature ratings for steel valves, the various rating classes for flanges provided an obviously logical basis for valve ratings. Steel valves with flanges of standard dimensions, many also offered in buttwelding-end versions, were given the same pressure-temperature ratings as the flanges. In 1949, a new edition of the standard, then designated B16e 1949, was published, in which a table covering wall thickness requirements for weld end valves had been added. In 1964, the Manufacturer's Standardization Society of the Valve and Fittings Industry developed and published Standard Practice SP 66, covering pressure-temperature ratings of steel buttwelding-end valves. SP 66 introduced a new method for establishing ratings by making ratings a function of the mechanical strength properties of the body material at all temperatures. Following the publication of SP 66, B16 activated Subcommittee 4 for the purpose of studying the general subject of pressure-temperature ratings and developing rational criteria for such ratings.

In the B16 charge to Subcommittee 15, it was established that the new standard would replace SP 66 and also remove the reference to buttwelding-end valves from B16.5. Flanged-end valves would continue to be covered in B16.5 but on a fully specified basis, rather than as an add-on.

As the work of the subcommittee got underway, concurrent action was initiated in Subcommittee 3 for revision of B16.5. Subsequent operations of Subcommittees 3 and 15 were closely coordinated to provide assurance that the new standard and the revised B16.5 would be compatible.

A key and basic issue of mutual concern in this coordination was the matter of pressure-temperature ratings. It was necessary to incorporate the SP 66 type ratings in the new standard, but at the same time also to provide ratings equivalent to those in B16.5 covering the buttwelding equivalents of flanged-end valves. Subcommittee 4 had made definitive recommendations for revisions in the flange ratings and it was obviously desirable to rationalize the two types of ratings as they would appear side-by-side in the new standard.

The results of these efforts appear herein in the form of pressure-temperature ratings tables. The method of computing the ratings is detailed in Annex F. The ratings differ from the pre-1968 B16.5 ratings because they are now calculated as a function of the mechanical properties of the pressure boundary materials, in contrast to the empirical basis used previously. A change in the SP 66 type rating (herein designated Special Class) discontinues the application of a plasticity factor at elevated temperatures which, in the opinion of the committee, could not be justified in dimension-sensitive valves.

Other innovations include the coverage of forged or fabricated body valves and an increase in detailed coverage by pressure-temperature ratings from 17 materials in B16.5 to 24 material groups in the new standard and in the revised B16.5. Dimensional requirements have been refined and augmented to give the designer more latitude and the user more assurance of adequacy. A number of the innovations have had trial use and at least some degree of acceptance, as they have been taken from the section on valve requirements developed and published by the ASME Boiler and Pressure Vessel Code to cover valves used in nuclear power plants. A section on valve testing eliminates uncertainties on such points as seat test requirements and stem seal testing.

Approval for the 1973 edition of the Standard by the American National Standards Institute was granted in October 1973.

In December 1973, a reorganization of the subcommittee structure for B16 was approved. Subcommittee 15 was redesignated as Subcommittee N and was assigned responsibility for all steel valves. Work began to include coverage for flanged-end valves in ANSI B16.34. The 1977 edition contained flanged-end valve requirements formerly in ANSI B16.5. The rating procedures of B16.5 were adopted and made applicable to Standard Class butt-welding-end valves. The method of deriving ratings was revised. Major changes were made in the method for determining ratings for austenitic stainless steel valves and ratings for Class 150 valves for all materials. The pressure-temperature tables and materials groups were rearranged and revised using data from the reference Sections of the ASME Boiler and Pressure Vessel Code through the Summer 1975 Addenda. A number of clarifying and editorial revisions were also made in order to improve the text. It was also resolved that frequent minor changes in pressure-temperature ratings because of revisions to the reference material strength property tables should be avoided and that, as a general guide, such changes should not be considered unless resulting ratings would be changed by an amount in excess of 10%.

Approval for the 1977 edition of the Standard by the American National Standards Institute was granted on June 16, 1977.

During 1979, work began on the 1981 edition. Materials coverage was expanded. Nickel alloys and other alloys were added. Bolting rules were revised to accommodate special alloy bolting for the new materials. Revisions were included to clarify requirements for rotary motion valves, e.g., ball valves and butterfly valves. Wafer-type valves were specifically identified. Other clarifying and editorial revisions were made in order to improve the text.

Following approvals by the Standards Committee and Secretariat, approval for the 1981 edition was granted by the American National Standards Institute on August 14, 1981.

During 1985, revisions were proposed that added requirements for socket welding-end and threaded-end valves. The inclusion of requirements for these valves increased the scope of the Standard. Also, the listings for nickel alloy and other alloy valves materials were expanded. Rules for threaded body joints were added, and wafer-type valve body rules improved.

Following approvals by the Standards Committee and ASME, approval for the 1988 edition was granted by the American National Standards Institute on February 24, 1988.

During 1993 and carrying over into 1994, revisions offered included multiple material marking and an improved interpolation procedure. New materials were added and the pressure-temperature rating tables were recalculated in accordance with Annex F using the latest data available from the reference ASME Boiler and Pressure Vessel Code sources. An Annex was added covering nonmandatory requirements for a quality system program.

Following the approvals the Standards Committee and ASME, approval for the new edition was granted by the American National Standards Institute on October 3, 1996.

All requests for interpretation or suggestions for revisions should be sent to the Secretary, B16 Committee, The American Society of Mechanical Engineers, Three Park Avenue, New York, NY 10016-5990.

**ASME B16 COMMITTEE**  
**Standardization of Valves, Flanges, Fittings, Gaskets, and Valve Actuators**

(a)

(The following is the roster of the Committee at the time of approval of this Standard.)

**OFFICERS**

**W. N. McLean, Chair**  
**R. A. Schmidt, Vice Chair**  
**P. A. Reddington, Secretary**

**COMMITTEE PERSONNEL**

**W. L. Ballis**, Consultant, London, Ohio  
**R. W. Barnes**, Anric Enterprises, Elobicoke, Ontario, Canada  
**R. R. Brodin**, Fisher Controls International, Inc., Marshalltown, Iowa  
**M. A. Clark**, NIBCO Inc., Elkhart, Indiana  
**C. E. Floren**, Mueller Co., Decatur, Illinois  
**D. R. Frikken**, Monsanto Co., St. Louis, Missouri  
**R. Henrich**, Minnegasco Inc., Golden Valley, Minnesota  
**J. C. Inch**, Mueller Brass Co., Hartsville, Tennessee  
**G. A. Jolly**, Vogt Valve Co., Louisville, Kentucky  
**W. G. Knecht**, BW/IP International Inc., Williamsport, Pennsylvania  
**R. Koester**, The William Powell Co., Cincinnati, Ohio  
**W. N. McLean**, Newco Valves, Palos Park, Illinois  
**M. L. Nayyar**, Bechtel Corp., Gaithersburg, Maryland  
**R. A. Schmidt**, Ladish Co., Russellville, Arkansas  
**T. F. Shroud**, Ductile Iron Pipe Research Association, Birmingham, Alabama  
**H. R. Sonderegger**, Grinnel Corp., Cranston, Rhode Island  
**W. M. Stephan**, Flexitalic, Inc., Pennsauken, New Jersey  
**M. D. Wasicek**, ABS Americas, Houston, Texas  
**R. E. White**, Repairs, Inc., South Bend, Indiana  
**D. A. Williams**, Southern Company, Services, Birmingham, Alabama  
**L. A. Willis**, Dow Chemical Co., Freeport, Texas  
**W. R. Worley**, Union Carbide Corp., South Charleston, West Virginia

**SUBCOMMITTEE N — STEEL VALVES**

**W. N. McLean**, *Chair*, Newco Valves, Palos Park, Illinois  
**U. D'Urso**, *Secretary*, ASME, New York, New York  
**E. A. Bake**, Consultant, Cary, North Carolina  
**D. R. Frikken**, Solutia, Inc., St. Louis, Missouri  
**G. R. Icenogle**, Fisher Controls International, Inc., Marshalltown, Iowa  
**G. A. Jolly**, Vogt Valve Co., Louisville, Kentucky  
**R. J. Kiessel**, Consultant, Livingston, Texas  
**W. G. Knecht**, BW/IP International Inc., Williamsport, Pennsylvania  
**M. L. Nayyar**, Bechtel Corp., Gaithersburg, Maryland

**F. R. O'Brien**, Crane Pacific Valves, Long Beach, California  
**G. J. Paptzun**, George J. Paptzun, PE, Lansdale, Pennsylvania  
**D. W. Raho**, CCM 2000, Rockaway, New Jersey  
**H. R. Sonderegger**, Grinnel Corp., Cranston, Rhode Island  
**F. C. Tsao**, Department of Navy, Washington, D.C.  
**M. D. Wasicek**, ABS Americas, Houston, Texas

## CONTENTS

Introductory Notes .....	iii
Foreword .....	v
Standards Committee Roster .....	vii
1 Scope .....	1
2 Pressure-Temperature Ratings .....	1
3 Size .....	4
4 Marking .....	4
5 Materials .....	5
6 Dimensions .....	6
7 Pressure Testing .....	10
8 Requirements for Special Class Valves .....	11
<b>Figures</b>	
1 Method of Designating Location of Auxiliary Connections When Specified .....	14
2 Thread Length for Auxiliary Connections .....	15
3 Socket Welding for Auxiliary Connections .....	15
4 Butt Welding for Auxiliary Connections .....	16
5 Bosses for Auxiliary Connections .....	16
6 Gate Body (Pressure Seal Bonnet) .....	17
7 Y Pattern Globe Body (Pressure Seal Bonnet) .....	17
8 Angle Body (Pressure Seal Bonnet) .....	18
9 Elbow Down (Pressure Seal Bonnet) .....	18
10 Gate Body (Flanged Bonnet) .....	19
11 Globe Body (Flanged Bonnet) .....	19
12 Butterfly Body .....	20
13 Plug Body .....	20
14 Conduit Gate Body (Pressure Seal Bonnet) .....	21
15 Dished Cover .....	21
16 Flat Cover .....	21
17 Butterfly Valve Body .....	22
<b>Tables</b>	
1 Material Specification List .....	23
2 Pressure-Temperature Ratings .....	31
3 Valve Body Minimum Wall Thickness $t_m$ , in. ....	89
4 Minimum Wall Thickness for Socket Welding and Threaded Ends .....	92
<b>Annexes</b>	
A Relationship Between Nominal Pipe Size and Inside Diameter .....	93
B Radiography Procedure and Acceptance Standards .....	95
C Magnetic Particle Examination Procedure and Acceptance Standards .....	97
D Liquid Penetrant Examination Procedure and Acceptance Standards .....	99

E	Ultrasonic Examination Procedure and Acceptance Standards .....	101
F	Methods for Establishing Pressure-Temperature Ratings .....	103
G	Requirements for Limited Class Valves .....	109
H	Quality System Program .....	113
I	Reference Standards and Specifications .....	115
<b>Interpretations .....</b>		<b>119</b>

# VALVES — FLANGED, THREADED, AND WELDING END

## 1 SCOPE

### 1.1 General

This Standard applies to new valve construction and covers pressure-temperature ratings, dimensions, tolerances, materials, nondestructive examination requirements, testing, and marking for cast, forged, and fabricated flanged, threaded, and welding end and wafer or flangeless valves of steel, nickel-base alloys, and other alloys shown in Table 1. Wafer or flangeless valves, bolted or through-bolt types, that are installed between flanges or against a flange shall be treated as flanged-end valves. Alternative rules for small valves (NPS 2½ and smaller) are given in Annex G.

### 1.2 Applicability

**1.2.1 Standards and Specifications.** Standards and specifications adopted by reference in this Standard and the names and addresses of the sponsoring organizations are shown in Annex I. It is not considered practical to refer to a specific edition of each of the standards and specifications in the individual references. Instead, the specific edition references are included in Annex I. A product made in conformance with a prior edition of reference standards and in all other respects conforming to this Standard will be considered to be in conformance even though the edition reference may have been changed in a subsequent revision of this Standard.

**1.2.2 Codes and Regulations.** A valve used under the jurisdiction of the ASME Boiler and Pressure Vessel Code, the ASME Code for Pressure Piping, or governmental regulations is subject to any limitation of that code or regulation. This includes any maximum temperature limitation for a material or rule governing the use of a material at a low temperature.

**1.2.3 Time of Purchase, Manufacture, or Installation.** The pressure-temperature ratings included in this Standard are applicable, upon its publication, to all valves covered within its scope which otherwise meet its requirements. For unused valves, valves that have been maintained in inventory, the manufacturer may certify conformance to this edition provided that it can be demonstrated that all requirements of this

edition have been met. However, where such components were installed under the pressure temperature ratings of an earlier edition of ASME B16.5 or ASME B16.34, those ratings shall apply except as may be governed by an applicable Code (see para. 1.2.2)

**1.2.4 User Accountability.** This Standard cites duties and responsibilities that are to be assumed by the valve user in the areas of, for example, application, installation, system hydrostatic testing, operation, and material selection.

**1.2.5 Quality Systems.** Requirements relating to the valve manufactures Quality System Programs are described in nonmandatory Annex H.

### 1.3 Service Conditions

Criteria for selection of valve types and materials suitable for particular fluid service are not within the scope of this Standard.

### 1.4 Convention

For the purpose of determining conformance with this Standard, the convention for fixing significant digits where limits, maximum and minimum values, are specified shall be "rounding off" as defined in ASTM Practice E 29. This requires that an observed or calculated value shall be rounded off to the nearest unit in the last right-hand digit used for expressing the limit. Decimal values and tolerance do not imply a particular method of measurement.

## 2 PRESSURE-TEMPERATURE RATINGS

### 2.1 General

Pressure-temperature ratings are designated by class numbers. Each class number is further identified as Standard, Special, or Limited Class. Ratings are tabulated in Tables 2 for Standard and Special Class 150, 300, 400, 600, 900, 1500, 2500, and 4500. Ratings for Limited Class are determined by the method of Annex G.

(a) Flanged end-valves shall be rated only as Standard Class.



(b) Class 4500 applies only to welding end-valves.

(c) A class designation greater than Class 2500 or a rating temperature greater than 1000°F applied to threaded-end valves is beyond the scope of this Standard.

(d) Threaded and socket welding-end valves larger than NPS 2½ are beyond the scope of this Standard.

(e) Except as provided in para. 2.5, the tabulated ratings are the maximum allowable working pressures, expressed as gage pressure, at the temperatures shown.

(f) Ratings intermediate to tabulated values are determined by linear interpolation between temperatures within a class number or between class numbers, except that for flanged-end valves interpolation between tabulated classes is not permitted.

(a) (g) In all cases, valves shall be constructed so that the body, bonnet or cover, body bolting, and bonnet or cover bolting meet the 100°F pressure rating requirements for the designated pressure class or pressure-temperature rating. However, pressure-temperature ratings for the valve may be otherwise limited by construction details or materials considerations, in which case the requirements of paras. 4.3.3 and 7.2.3 shall be met.

**2.1.1 Standard Class Valves.** Valves conforming to the requirements of this Standard, except for those meeting the additional requirements of Section 8 for Special Class valves or of Annex G for Limited Class valves, shall be designated Standard Class valves. Ratings shall not exceed the values shown in those Tables 2 having an identifying suffix "A".

**2.1.2 Special Class Valves.** Threaded- or welding-end valves which conform to all the requirements of para. 2.1.1, and in addition have successfully passed the examinations required by Section 8, may be designated Special Class valves. Ratings shall not exceed the values shown in those Tables 2 having an identifying suffix "B". Special Class ratings shall not be used for flanged-end valves.

**2.1.3 Limited Class Valves.** Welding- or threaded-end valves in sizes NPS 2½ and smaller that conform to the requirements of Annex G may be designated Limited Class valves. Ratings shall not exceed the values calculated in accordance with Annex G. Limited Class ratings shall not be used for flanged-end valves.

**2.1.4 Intermediate Rated Valves.** A welding- or threaded-end valve may be assigned an intermediate pressure-temperature rating or Class, either Standard or Special, in accordance with para. 6.1.4, provided all other applicable requirements of this Standard are met. Correspondingly, an intermediate rating or Class for

Limited Class valves may be assigned using pressure-temperature ratings as determined by the method described in Annex G in conjunction with the interpolation procedure described in para. 6.1.4.

**2.1.5 Valves Fabricated by Welding.** A valve made wholly or partly from segments of castings, forging, bars, plates, or tubular product welded together will merit the applicable ratings only if:

(a) it conforms to all applicable requirements of this Standard;

(b) weld fabrication and heat treatment of welds are in accordance with the ASME Boiler and Pressure Vessel Code, Section VIII, Division 1;

(c) nondestructive examination of welds is in accordance with the ASME Boiler and Pressure Vessel Code, Section VIII, Division 1, as required to warrant a joint efficiency E not less than:

(1) 0.80 for flanged-end and Standard Class welding-end valves larger than size NPS 6;

(2) 1.00 for Special Class welding-end or threaded-end valves in all sizes (see para. 8.3.3).

These requirements are not applicable to seal welds or attachment welds such as for backseat bushings, seat rings, lifting lugs, and auxiliary connections.

## 2.2 Rating Temperature

The temperature shown for a corresponding pressure rating is the temperature of the pressure-containing shell of the component. In general, this temperature is the same as that of the contained fluid. Use of a pressure rating corresponding to a temperature other than that of the contained fluid is the responsibility of the user, subject to the requirements of applicable codes and regulations.

## 2.3 Temperature Effects

Some considerations of the effect of temperature in application are given below. Additional guidance can be found in ASME B16.5 as related to line flange joints.

**2.3.1 High Temperature.** Application at temperatures in the creep range will result in decreasing bolt loads as relaxation of flanges, bolts, and gaskets takes place. Flanged joints subject to thermal gradients may likewise be subject to decreasing bolt loads. Decreased bolt loads diminish the capacity of the flanged joint to sustain loads effectively without leakage. At elevated temperatures, flanged joints, and in particular Class 150, may develop leakage problems unless care is taken

to avoid imposing severe external loads or severe thermal gradients.

**2.3.2 Low Temperature.** For a material shown in Table 1, the pressure rating for service at any temperature below  $-20^{\circ}\text{F}$  shall be no greater than the rating shown in the table for  $-20^{\circ}\text{F}$ . Some of the materials listed in Table 1, notably some carbon steels, may undergo a decrease in ductility when used at low temperatures to such an extent as to be unable to safely resist shock loading, sudden change of stress, or high stress concentration. Some codes or regulations may require impact testing for applications even where temperatures are higher than  $-20^{\circ}\text{F}$ . When such requirements apply, it is the responsibility of the user to ensure these requirements are communicated to the manufacturer prior to the time of purchase.

**2.3.3 Fluid Thermal Expansion.** Under certain conditions, some double-seated valve designs are capable of sealing simultaneously against pressure differential from the center cavity to the adjacent pipe in both directions. A circumstance in which the center cavity is filled or partially filled with liquid and subjected to an increase in temperature can result in an excessive buildup of pressure in the center cavity leading to pressure boundary failure. An example is a piping system in which liquid from the condensing, cleaning, or testing fluids accumulates in the center cavity of a closed valve. Such accumulation may result from leakage past the upstream seat of the valve. If, during subsequent startup, the valve is not relieved of the liquid by partial opening of the valve, or by some other method, the retained liquid may be heated during warmup of the system. Where such a condition is possible, it is the responsibility of the user to provide, or require to be provided, means in design, installation, or operation procedure to assure that the pressure in the valve will not exceed that allowed by this Standard for the attained temperature.

## 2.4 Guidance for the Use of Flanged Valve Ratings

Application of flanged-end valves at either high or low temperatures or in a service subject to rapid fluid temperature variations entails some risk of flanged joint leakage. Guidance, which is intended to minimize these risks, is provided in ASME B16.5. Precautions regarding the bolting of raised face flanges to cast iron flanges are given in ASME B16.5.

## 2.5 Variances

Except as provided in paras. 2.5.1, 2.5.2, and 2.5.3, the ratings are the maximum allowable working pressure for the corresponding temperature.

**2.5.1 Safety Valve, Relief Valve, or Rupture Disk Operation.** Under conditions of safety valve, relief valve, or rupture disk operation, the pressure may exceed the rated pressure for a valve furnished under this Standard by no more than 10% of that defined by the pressure-temperature rating. Such conditions are necessarily of limited duration. Pressure excursions in excess of the aforementioned are solely the responsibility of the user.

**2.5.2 Other Variances.** Subjecting a valve to operating variances (transients) in excess of its rating is solely the responsibility of the user.

**2.5.3 System Hydrostatic Tests.** If valves conforming to this Standard are subjected to hydrostatic pressure testing of systems with the valve in the closed position at pressures greater than the  $100^{\circ}\text{F}$  rating, or, if applicable, at pressure greater than the closed pressure differential shown on the valve identification plate (see para. 4.3.3), such testing will be the responsibility of the user. In the open position, valves installed in a piping system may be subjected to system tests as conditions not to exceed the hydrostatic shell test of para. 7.1, provided the user has determined that there are no functional limitations, for example, restrictions on actuating devices or special materials of construction.

## 2.6 Multiple Material Grades

Material for valve bodies, bonnets, or cover plates may meet the requirements of more than one ASTM specification or the requirements of more than one grade of an ASTM specification listed in Table 1. In either event, the pressure-temperature ratings for any of these specifications or grades may be used provided the requirements of para. 5.1 are satisfied, the material is marked in accordance with para. 4.2.8, and account is taken of para. 5.2.2.

## 2.7 Local Operating Conditions

When a valve (or series of valves) is installed in a piping system that operates with different pressures (or temperatures) on either side of the closed valve, it is the responsibility of the user to ensure that the installed valve is suitable for the highest of the rating require-

ASME B16.34-1996

VALVES — FLANGED,  
THREADED, AND WELDING END

ments considering combinations of pressure and temperature.

### 3 SIZE

#### 3.1 Nominal Pipe Size

As applied in this Standard, the use of the phrase "nominal pipe size" is intended to indicate that the stated number is used for purposes of pipe or flange-end connection identification and is not necessarily the same as the valve inside diameter. The relationship between inside diameter (see para. 6.1.2) and nominal pipe size is shown in Annex A. The abbreviation NPS is also used to indicate nominal pipe size. The reference dimension in Table 3 is the inside diameter as defined in para. 6.1.2.

### 4 MARKING

#### 4.1 General

Except as may be modified herein, valves shall be marked as required in MSS SP-25 and shall include the following requirements.

#### 4.2 Identification Markings

**4.2.1 Name.** The manufacturer's name or trademark shall be shown.

**4.2.2 Materials.** Materials used for valve bodies, bonnets, and cover plates shall be identified in the following way.

(a) Cast valves shall be marked with the heat number or heat identification and symbols as given in the ASTM specification to designate the material grade.

(b) Forged or fabricated valves shall be marked with the ASTM specification number<sup>1</sup> and grade identification symbol. When more than one material or grade of materials is used, each shall be identified.

(c) A manufacturer may supplement these mandatory material identifications with his trade designation for the material grade, but confusion with the marking required herein shall be avoided.

<sup>1</sup> The ASME Boiler and Pressure Vessel Code, Section II specification number may be substituted provided that the material under consideration is covered by Section II.

**4.2.3 Rating.** The valve body shall be marked with the number that corresponds to the pressure rating class designation except that Special Class, Limited Class, Intermediate Rated — Standard Class and Intermediate Rated — Special Class valves may instead be marked with a specific rated pressure and temperature.

**4.2.4 Temperature.** No temperature markings are required except as indicated in paras. 4.2.3 and 4.3.3.

**4.2.5 Size.** The nominal size identification number shall be shown.

**4.2.6 Omission of Markings.** On valves whose size or shape limits the body markings, they may be omitted in the following order:

- (a) size
- (b) rating
- (c) material
- (d) manufacturer's name or trademark

**4.2.7 Ring-Joint-End Flange.** Valves having ring-joint-end flanges shall have the edge (periphery) of each ring-joint-end flange marked with the letter "R" and the corresponding ring-groove number (see ASME B16.5).

**4.2.8 Multiple Material Marking.** Material for valve bodies, bonnets, and cover plates which meet the requirements for more than one grade of an ASTM specification listed in Table 1 may, at the manufacturer's option, be marked with more than one of the applicable grade symbols. The grade symbols shall be placed to avoid confusion in identification.

#### 4.3 Identification Plate

**4.3.1 Attachment.** An identification plate that includes the valve manufacturer's name shall be secured to each valve.

**4.3.2 Cold Working Pressure.** The identification plate shall be marked with the applicable valve pressure rating at 100°F and the pressure rating class number.

**4.3.3 Special Markings.** Valves whose construction limits use to less than the pressure-temperature values for the marked pressure rating class designation shall indicate these limitations on the identification plate. Examples in this category are valves using elastomeric gaskets or seating elements, valves with closure elements designed for closure pressure differentials lower than the basic rated pressure of the valve body, or valves

using carbon steel bonnet bolts such as ASTM A 307, Grade B.

#### 4.4 Conformity

**4.4.1 Designation.** Valves conforming to Standard Class requirements shall include the designation "B16.34" on the identification plate. For all Special Class valves, the identification plate shall include the designation "B16.34 SPL". For all Limited Class valves, the identification plate shall include the designation "B16.34 LTD". The use of the prefix "ASME" to these designations is optional.

**4.4.2 Compliance.** The "B16.34" identification marking of para. 4.4.1 designates that the valve was manufactured in conformance with ASME B16.34.

### 5 MATERIALS

#### 5.1 General

The body, bonnet or cover, body joint bolting, and body-bonnet or cover bolting, shall be constructed of materials as listed in the respective ASTM specifications referred to in Table 1. Identical materials in accordance with the ASME Boiler and Pressure Vessel Code Section II may also be used for these parts. It is not required that identical material or material form be used for body and bonnet or cover parts. The rating applied, however, shall be based on the valve body. The bonnet or cover shall be designed and material selected accordingly. Selection of stems, disks, and other parts, such as bonnet gaskets and bolting, subject to pressure and other loading, must be consistent with the applicable valve pressure-temperature rating.

##### 5.1.1 Carbon Steel Bonnet or Cover Bolting.

It is permissible to use carbon steel, for example, ASTM A 307, Grade B, for bonnet or cover bolting only for Class 300 and lower, provided the service temperature is limited to 400°F and marking is in accordance with para. 4.3.3.

- (a) **5.1.2 Investment Castings.** When investment castings are used for bodies, bonnets, and cover plates of valves in sizes NPS 4 and smaller where the ratings do not exceed Class 600, the requirements of the ASTM specifications referred to in Table 1 shall be met, except that it is permissible to determine mechanical and chemical properties from a master heat and to use a 1 in. × 0.25 in. diameter tensile specimen in place of the standard 2 in. tensile specimen. A master heat is

previously refined metal of a single furnace charge. Tensile specimens shall be cast in molds of the same refractory as the castings and shall be given the same heat treatment as the castings. When investment castings are used for sizes and pressure classes greater than those described above, all the requirements of the applicable Table 1 ASTM specification shall be met.

**5.1.3 Cast Surfaces.** Cast surfaces of pressure boundary parts shall be in accordance with MSS SP-55.

**5.1.4 Mechanical Properties.** Mechanical properties shall be obtained from test specimens that represent the final heat-treated condition of the material required by the material specification.

#### 5.2 Material Selection

**5.2.1 Service Conditions.** Criteria for the selection of materials are not within the scope of this Standard. The possibility of material deterioration in service and the need for periodic inspections is the responsibility of the user. Carbide phase conversion to graphite, oxidation of ferritic materials, decrease in ductility of carbon steels at low temperature (even in applications above 20°F), and susceptibility to intergranular corrosion of austenitic materials or grain boundary attack of nickel-base alloys are among those items requiring attention by the user. A discussion of precautionary considerations can be found in Appendix F of ASME B31.3.

**5.2.2 Responsibility.** When service conditions dictate the implementation of special material requirements, e.g., using a Group 2 material above 1000°F, it is the user's responsibility to so specify to the manufacturer in order to ensure compliance with metallurgical requirements listed in the end notes to Table 1 and the notes in Table 2.

#### 5.3 Electrical Continuity

Internal parts that are insulated from the valve body may build up a static electric charge. An example is a ball valve with seats and seals of nonconductive materials. When service conditions require electrical continuity to prevent static discharge, the user is responsible for specifying static grounding.

#### 5.4 Flange Removal

When an end flange is removed from a flanged-end valve body casting to make a weld-end valve casting, discontinuities may be observed that would not have

responsibility for the acceptability of the resultant weld-end valve casting. This responsibility includes pressure testing the resultant weld-end valve in accordance with Section 7.

## 6 DIMENSIONS

### 6.1 Body Dimensions

**6.1.1 Wall Thickness.** For inspection purposes, the wall thickness of valve bodies at the time of manufacture shall be no less than the minimum values  $t_m$  shown in Table 3, except as indicated in paras. 6.1.3 through 6.1.7, 6.2, and 6.7. When using the table, linear interpolation may be used for values intermediate to those listed. The minimum thickness requirement for the body wall is applicable only as measured from internal wetted surfaces. Minimum wall thickness shall not include liners, linings, or cartridges.

**6.1.2 Inside Diameter.** For the purpose of determining the wall thickness  $t_m$ , the inside diameter  $d$  is taken as the minimum diameter of the flow passage but not less than 90% of the basic inside diameter at the valve end. For socket welding- and threaded-end valves, the socket or thread diameters and associated counterbores or tapped bores need not be considered in establishing the value of  $d$  (see paras. 6.2.3 and 6.2.4). For the special case of valves used between high and low pressure sections of a system where an end connection is specified for a thinner pipe wall (or lower class flange) on one end than on the other, the inside diameter  $d$  shall be based on the end connection with the heavier pipe wall (or higher class flange). Localized variations of inside diameter associated with transitions to weld preparations need not be considered. Note, however, limitations of proximity of body neck in para. 6.1.5. Where linings, liners, or cartridges are used to form the flow passage or portions of the flow passage, the inside diameter  $d$  shall be that at the liner-body interface. For inside diameters which lie BETWEEN diameters for which minimum wall thickness is tabulated,  $t_m$  may be determined by linear interpolation.

**6.1.3 Valve Body Necks.** Valve body necks shall maintain the minimum wall thickness as described in paras. 6.1.1 and 6.1.2 within a region of  $1.1\sqrt{dt_m}$  measured from the outside of the body run along the neck direction. The diameter,  $d$ , is as defined in para. 6.1.2, and  $t_m$  is the minimum wall thickness as shown in Table 3. Minimum wall thickness requirements are

applicable to and measured from internally wetted surfaces, e.g., up to the point where the body-bonnet seal is affected.

Beyond the aforementioned  $1.1\sqrt{dt_m}$  region, straight circular sections of valve body necks with inside diameter  $d'$  shall be provided with local wall thickness at least equal to  $t'$  where  $t'$  is taken from the appropriate (tabulated or intermediate) rating Class in Table 3 using an appropriate diameter  $d''$ .

For rating of Class 150 to 2500:

$$d'' = \frac{2d'}{3}$$

For ratings over Class 2500:

$$d'' = \frac{d'}{48} \left( 27 + \frac{P_c}{500} \right)$$

where  $P_c$  is the pressure class designation as defined in Annex F, para. F1.3.

(a) For the special case where  $d' > 1.5d$ , it is necessary that the wall thickness be equal to or greater than  $t'$  for the entire body neck length having diameter  $d'$ , including the aforementioned  $1.1\sqrt{dt_m}$  region.

(b) For the special case of valve body necks having a small diameter relative to the body run diameter, that is,  $d/d' \geq 4$  (for example, a butterfly valve stem penetration), the minimum local wall thickness within the region of  $t_m(1 + 1.1\sqrt{dt_m})$ , measured starting from the intersection of the body inside diameter and the axis of the body neck diameter, shall be equal to  $t'$  where  $t'$  is obtained from Table 3 using the appropriate body neck inside diameter  $d'$  and the appropriate pressure class. This special case is illustrated in Fig. 16. Beyond the aforementioned region of  $t_m(1 + 1.1\sqrt{dt_m})$ , valve body necks shall be provided with local minimum wall thickness based on  $d''$ , in accordance with para. 6.1.3.

(c) For the special case of a body neck in which holes are drilled or tapped in the body neck wall parallel with the body neck axis, it is required that the sum of the ligaments at the inner and outer sides be equal to or greater than  $t_m$  or  $t'$ , as applicable. The inner ligament and the ligament at the bottom of the drill hole shall be no less than  $0.25t_m$  or  $0.25t'$ , as

applicable. Furthermore, it is required that this thickness shall extend for a length along the body neck, starting at the top of the neck, at least equal to the depth of the hole plus a distance equal to one-half of the hole or bolt diameter.

**6.1.4 Welding or Threaded End Valves With Intermediate Ratings.** The intermediate pressure rating class designation,  $P_{rd}$ , and minimum wall thickness,  $t_m$ , for threaded- or welding-end valves with intermediate pressure ratings shall be determined by linear interpolation. The method is illustrated in (a) and (b) below.

(a) Enter the appropriate pressure-temperature rating table of Tables 2 with the design temperature and working pressure  $P_d$ , and determine the pressure rating  $P_1$ , next below, and  $P_2$ , next above  $P_d$ , where  $P_1$  and  $P_2$  are ratings corresponding to pressure class designations  $P_{r1}$  and  $P_{r2}$ . Determine the intermediate pressure rating class designation,  $P_{rd}$ , corresponding to design conditions using

$$P_{rd} = P_{r1} + \frac{(P_d - P_1)}{(P_2 - P_1)} (P_{r2} - P_{r1})$$

(b) Using the appropriate inside diameter,  $d$ , in Table 3, select the minimum wall thicknesses  $t_1$  and  $t_2$  corresponding to pressure classes  $P_{r1}$  and  $P_{r2}$  respectively. Determine the minimum wall thickness,  $t_m$ , corresponding to design conditions using

$$t_m = t_1 + \frac{(P_{rd} - P_{r1})}{(P_{r2} - P_{r1})} (t_2 - t_1)$$

**6.1.5 Contours at Body Ends**

(a) *Buttwelding Ends.* The weld preparation (see para. 6.2.1) shall not reduce the body wall thickness to less than the values required by para. 6.1.1 or 6.1.4 within a region closer to the outside surface of the body neck than  $t_m$  measured along the run direction. The transition to the weld preparation shall be gradual and the section must be essentially circular through the entire length of the transition. Sharp discontinuities or abrupt changes in sections that infringe into the transition shall be avoided, except that test collars or bands, either welded or integral, are allowed. In no case shall the thickness be less than  $0.77t_m$  at a distance of  $1.33t_m$  from the weld end.

(b) *Socket Welding and Threaded Ends.* The distance from the center line of generally cylindrical flow passages to the external surface of the body run shall be no less than 0.5 times the appropriate nominal pipe outside diameter listed in ANSI/ASME B36.10M.

(c) *Completed Ends.* After the tests required by para. 7.1 have been completed, and at the manufacturer's discretion, semifinished buttwelding ends may be machined to final dimensions, flange gasket seating surfaces may be machined to a final surface finish or threaded ends may be converted to socket welding ends, all without any additional pressure testing.

**6.1.6 Local Areas.** Local areas having less than minimum wall thickness will be acceptable provided that all of the following limitations are satisfied.

(a) The area of subminimum thickness can be enclosed by a circle whose diameter is no greater than  $0.35 \sqrt{d_o t_o}$ . For valve body necks, use  $d_o = d'$  and  $t_o = t'$  (see para. 6.1.3). For all other local areas, use  $d_o = d$  (see para 6.1.2) and  $t_o = t_m$  (see para. 6.1.1 or 6.1.4, as appropriate);

(b) Measured thickness is no less than  $0.75t_o$ ;

(c) Enclosure circles are separated from each other by an edge-to-edge distance of no less than  $1.75 \sqrt{d_o t_o}$ .

**6.1.7 Additional Metal Thickness.** Additional metal thickness needed, for example, for assembly loads, actuating (closing and opening) loads, shapes other than circular, and stress concentrations, must be determined by individual manufacturers since these factors vary widely. In particular, inclined stem valves, intersections and openings in enlarged body cavities, and some types of fabricated body valves may require additional reinforcement to assure adequate strength and rigidity.

**6.2 End Dimensions**

**6.2.1 Buttwelding Ends.** Unless otherwise specified, the details of the welding-end preparation shall be in accordance with ASME B16.25, with the inside diameter (denoted as dimension  $B$  in ASME B16.25) having the following tolerance:

- (a) sizes NPS 10 smaller:  $\pm 0.03$  in.
- (b) sizes NPS 12 to 18:  $\pm 0.06$  in.
- (c) sizes NPS 20 and larger:  $+0.12, -0.06$  in.

In all cases, the thickness of the body run or nozzle transition (see para. 6.1.5) starting at a distance  $1.33t_m$  from the buttwelding end, shall be no less than  $0.77t_m$ .

**6.2.2 Flanged Ends.** Flanged ends shall be prepared with flange facing, nut-bearing surfaces, outside diameter, thickness, and drilling in accordance with ASME B16.5 requirements for flanged fittings. When required, end flanges may be furnished with tapped

holes for flange bolting. Thread engagement in a pipe flange assembly with tapped holes shall provide full effective thread engagement, not including the chamfered threaded, for a length at least equal to the nominal diameter of the thread. For additional considerations, see para. 6.4.3.

**6.2.3 Socket Welding Ends.** The socket bore diameter, depth of socket, and end surfaces shall be in accordance with ASME B16.11. The minimum thickness of the socket wall extending over the socket depth, including any associated counterbore, shall be in accordance with Table 4.

**6.2.4 Threaded Ends.** End connections shall have taper pipe threads in accordance with ANSI/ASME B1.20.1. The minimum thickness of the wall extending over the length of the thread, including any associated tap bore or counterbore, shall be in accordance with Table 4. Thread lengths and gaging requirements shall be in accordance with ASME B16.11.

**6.2.5 Intermediate Rated Socket Welding and Threaded-End Valves.** The minimum socket wall thickness and the minimum threaded-end wall thickness for valves with intermediate ratings may be determined by interpolation using the method of para. 6.1.4(b) using wall thickness values from Table 4.

**6.2.6 End to End.** End-to-end dimensions and face-to-face dimensions shall be in accordance with ASME B16.10 or other dimensions by agreement between manufacturer and purchaser. For some valve types, both long and short pattern dimensions are listed in ASME B16.10. It should not be assumed that all designs of the type listed can be accommodated in the short pattern dimension series. For example, full port top entry ball valves cannot, in all cases, be fitted to the short pattern dimensions. For valves not included in ASME B16.10, dimensions shall be the manufacturer's standard.

## 6.3 Auxiliary Connections

**6.3.1 General.** Auxiliary connections shall be designed, fabricated, and examined so as to warrant at least the same pressure-temperature ratings as the valve and shall be installed prior to the shell test of the valve to which they are attached, except that upon agreement between the manufacturer and purchaser, auxiliary connections installed after the valve shell tests are acceptable. Welded auxiliary connections shall be made by a qualified welder using a qualified welding

procedure, both in accordance with ASME Boiler and Pressure Vessel Code, Section IX.

**6.3.2 Pipe Thread Tapping.** Holes may be tapped in the wall of a valve if the metal is thick enough to allow the effective thread length specified in Fig. 2. Where metal thickness is insufficient or the tapped hole needs reinforcement, a boss shall be added as shown in Fig. 5.

**6.3.3 Socket Welding.** Sockets may be provided in the wall of a valve if the metal is thick enough to accommodate the depth of socket and retaining wall specified in Fig. 3. Where the metal thickness is insufficient or the socket opening requires reinforcement, a boss shall be added as shown in Fig. 5. The length of the leg of the attachment weld shall be not less than 1.09 times the nominal pipe wall thickness of the auxiliary connection or 0.12 in., whichever is greater.

**6.3.4 Butt Welding.** Auxiliary connections may be attached by butt welding directly to the wall of the valve (see Fig. 4). Where the size of the opening is such that reinforcement is necessary, a boss shall be added as shown in Fig. 5.

**6.3.5 Bosses.** Where bosses are required, the inscribed diameters shall be not less than those shown in Fig. 5 and the height shall provide metal thickness to satisfy the requirements of Fig. 2 or 3.

**6.3.6 Size.** Unless otherwise specified, auxiliary connections shall be as follows:

Valve Size, NPS	Connection, NPS
2-4	$\frac{1}{2}$
5-8	$\frac{3}{4}$
10 and up	1

**6.3.7 Designating Locations.** A means of designating locations for auxiliary connections for some valve types is shown in Fig. 1. Each of these locations is designated by a letter so that the desired locations for the illustrated types of valves may be specified without using further sketches or description.

## 6.4 Valve Joints

Valves with bolted or threaded bonnet, cover, or body joints shall meet the requirements of this subsection.

**6.4.1 Bonnet or Cover Joints.** Valve bonnet or cover joints are joints that are not subject to direct piping loads.

(a) *Bolted Bonnet or Cover Joints.* Bolting shall be threaded in accordance with ANSI B1.1 and, as a minimum, shall satisfy the following bolt cross-sectional area requirements:

$$P_c \frac{A_g}{A_b} \leq 0.45S_a \leq 9000$$

(b) *Threaded Bonnet or Cover Joints.* Thread shear area, as a minimum, shall satisfy the following.

$$\frac{P_c A_g}{A_s} \leq 4200$$

where

$S_a$  = allowable bolt stress at 100°F, psi (when greater than 20,000 psi, use 20,000 psi)

$P_c$  = pressure rating class designation, psi (see Annex F, para. F1.3)

$A_g$  = area bounded by the effective outside periphery of a gasket or O-ring or other seal effective periphery, except that in the case of a ring-joint the bounded area is defined by the pitch diameter of the ring, sq in.

$A_b$  = total effective bolt tensile stress area, sq in.

$A_s$  = total effective thread shear area, sq in.

The allowable stress values shall be taken from the ASME Boiler and Pressure Vessel Code, Section VIII, Division 1, or Section III, Division 1, Class 2 or Class 3.

**6.4.2 Body Joints.** Valves with bodies of sectional construction such that bolted or threaded body joints are subject to piping mechanical loadings shall, as a minimum, satisfy the following requirements.

(a) *Bolted Body Joints.* Bolted body joints shall use bolting threaded in accordance with ANSI B1.1 and shall, as a minimum, satisfy the following bolt cross-sectional area requirement.

$$P_c \frac{A_g}{A_b} \leq 0.35S_a \leq 7000$$

(b) *Threaded Body Joints.* Threaded body joints shall, as minimum, satisfy the following thread shear area requirement.

$$P_c \frac{A_g}{A_s} \leq 3300$$

**6.4.3 Additional Considerations.** Bolting or threading in excess of the minimum requirements of this Standard may be required because of valve design, special gasket compression requirements, or special

specified service conditions. Since these factors vary widely, these requirements must be determined by individual manufacturers.

## 6.5 Stems

Special consideration for stems for certain valve types shall be as follows.

**6.5.1 Stem Retention.** Valves shall be designed so that the stem seal retaining fasteners (e.g., packing gland fasteners) alone do not retain the stem. Specifically, the design shall be such that the stem shall not be capable of removal from the valve, while the valve is under pressure, by the removal of the stem seal retainer (e.g., gland) alone.

**6.5.2 Position Indication.** Valves of the quarter-turn type (e.g., ball, plug, or butterfly) shall have a means to indicate the ball, plug, or disk position. The design shall be such that the components of the indicating means cannot be assembled to falsely indicate the valve open or closed position.

## 6.6 Installation Limitations

**6.6.1 Single Flange Installation.** Flanged and wafer or flangeless valves are intended for installation between flange pairs. These valves, however, can also be designed for installation against a single flange for the purpose of effecting closure in dead-end piping. Valves for the latter service shall be designed such that all parts which are necessary to support pressure loads acting across the seating element safely support the maximum differential pressure rating of the valve. Examples of such parts are end entry threaded seat retaining ferrules of ball valves and bolted seat seal retaining plates of butterfly valves. In the event that the valve design cannot accommodate these pressure loads, then the valve shall be marked to show such installation restriction.

**6.6.2 Disk Clearance.** Valves that can be bolted between flanges or against a flange (e.g., butterfly or swing check valves) may have a disk that will, upon rotation, project beyond the plane of the flange gasket. The valve design shall be such that there will be no interference between the valve disk and companion flanges or adjacent piping for the following pipe schedules.



Pressure Class	Valve Size, NPS	Pipe Schedule
150	2-24	40
300	2-24	80
600	2-6	80
600	8-14	100

For other valve sizes and pressure classes, pipe inside diameter and disk clearance shall be as agreed between manufacturer and purchaser.

**(a) 6.7 Wafer or Flangeless Valves**

The design of valves that can be bolted between flanges or against a flange (e.g., butterfly valves) shall conform to the applicable requirements for flanged valves and the requirements of (a) through (g) below (see Fig. 17).

(a) The design shall provide for boltup using all of the bolt holes and bolt circle of the specified flange.

(b) Bolt holes, parallel to the body run, may be either threaded or unthreaded. Threaded holes may be blind holes suitable for use with bolt studs. When threaded, full-thread engagement, excluding chamfers, shall be provided to a depth not less than one nominal bolt diameter.

(c) The required minimum valve body wall thickness  $t_m$  shall be measured from the valve body inside circumference out to the lesser of the valve body outside circumference or the circumference of a circle inscribed through the inner tangent points to the flange bolt holes.

(d) The inner ligament (*e* of Fig. 17) of either a through-hole or a blind threaded hole in the vicinity of a stem penetration shall not be less than 25% of the required wall thickness of body neck but in no case less than 0.1 in.

(e) The inner ligament (*f* of Fig. 17) for holes parallel to the body run shall not be less than  $0.25t_m$  but in no case less than 0.1 in. The sum of the inner and outer ligaments shall not be less than  $t_m$ .

(f) A ligament within the minimum body wall between two adjacent holes within the minimum body wall (*j* of Fig. 17) shall be  $0.25t_m$  or greater but not less than 0.1 in.

**(a)**

**7 PRESSURE TESTING**

**(a) 7.1 Shell Test**

Each valve shall be given a shell test at a gage pressure no less than 1.5 times the 100°F rating, rounded off to the

next higher 25 psi increment. The test shall be made with water, which may contain a corrosion inhibitor, with kerosene, or with other suitable fluid,<sup>2</sup> provided such fluid has viscosity not greater than that of water, at a temperature not above 125°F. Visually detectable leakage through pressure boundary walls is not acceptable. Test duration shall be not less than shown below.

Valve Size, NPS	Test Time, sec
2 and smaller	15
2.5-8	60
10 and larger	180

Test shall be made with the valve in the partially open position. Leakage through the stem packing shall not be cause for rejection, however, stem seals shall be capable of retaining pressure at least equal to the 100°F ratings without visible leakage.

**7.2 Valve Closure Tests<sup>3</sup>**

Each valve designed for shut-off or isolation service, such as a stop valve, and each valve designed for limiting flow reversal, such as a check valve, shall be given a closure test. The test fluid shall be as in para. 7.1. The test pressure shall be not less than 110% of the 100°F rating except that, at the manufacturer's option, a gas closure test at gage pressure not less than 80 psi may be substituted for valve sizes and pressure classes shown below.

Valve Size, NPS	Pressure Class
12 and smaller	400 and lower
4 and smaller	All

The closure test shall follow the shell test except that for valves NPS 4 and smaller with ratings Class 1500 and lower the closure test may precede the shell test when a gas closure test is used. The closure test duration shall be not less than shown below.

Valve Size, NPS	Test Time, sec
2 and smaller	15
2½-8	30
10-18	60
20 and larger	120

<sup>2</sup> There are hazards involved when gas is used as the fluid for testing. Appropriate precautions are required when a gas is used.

<sup>3</sup> Closure tightness requirements vary with intended service application and are not considered to be within the scope of this Standard. For guidance in this regard see, for example, MSS SP-61 or API-598.

VALVES — FLANGED  
THREADED, AND WELDING END

ASME B16.34-1996

The test time is the period of inspection after the valve is fully prepared and is under full pressure.

**7.2.1 Double Seating.** For valves of the double seating type, such as most gate and ball valves, the test pressure shall be applied successively on each side of the closed valve. As an alternate method, for valves with independent double seating (such as double disk gate valves), the pressure may be applied inside the bonnet or body with the disks closed.

**7.2.2 Directional Seating.** For other valve types, the test pressure shall be applied across the closure member in the direction producing the most adverse seating condition. For example, a globe valve shall be tested with pressure under the disk. A check valve, globe valve, or other valve type designed to be sold and marked as a one-way valve requires a closure test only in the appropriate direction.

**7.2.3 Restricted Seating.** Valves conforming to this Standard in all respects, except that they are designed for operating conditions that have the pressure differential across the closure member limited to values less than the 100°F pressure rating and have closure members and/or actuating devices (direct, mechanical, fluid, or electrical) that would be subject to damage at high differential pressures, shall be tested as described above except that the closure test requirement may be reduced to 110% of the maximum specified closed position differential pressure. This exception may be exercised as agreed between the user and manufacturer. The manufacturer's nameplate data shall include reference to any such limitations (see para. 4.3.3).<sup>4</sup>

### 7.3 Leakage Detection Devices

Leakage detection devices, e.g., pressure decay devices, may be used for detecting leakage provided that they are used at the pressures required for the shell and closure tests of paras. 7.1 and 7.2. When used, the valve manufacturer shall have demonstrated that the test results are equivalent to the requirements of paras. 7.1 and 7.2.

### 7.4 Surface Protection

Valves shall not be painted or otherwise coated with materials capable of sealing against leakage before the shell tests are completed except that:

<sup>4</sup> Performance testing of valve actuating devices is not within the scope of this Standard.

(a) internal linings or coatings included in the design, e.g., nonmetal butterfly valve linings, are permitted;  
(b) chemical corrosion protection treatment is permitted; and

(c) assembled valves having bodies and bonnets or cover plates that have been separately tested in accordance with para 7.1, prior to having been painted or coated, may be painted or coated prior to final testing in accordance with para. 7.1.

## 8 REQUIREMENTS FOR SPECIAL CLASS VALVES

### 8.1 Scope

This Section defines the nondestructive examination (NDE) requirements and the rules for defect removal and repair for cast, forged, rolled, wrought, and fabricated valve bodies and bonnets or covers which are intended for use in Special Class valves.

### 8.2 General

These examinations are to be performed on the cast, rolled, wrought, forged, or fabricated material after heat treatment required by the material specification either prior to or after the finish machining at the option of the manufacturer. Surfaces shall be clean and free of surface conditions which may mask unacceptable indications. Accessible surfaces (see paras. 8.3.1.2, and 8.3.2.2) do not include threads, drilled or threaded holes, for example, for bolting, packing, stems, or auxiliary connections.

### 8.3 Required Examination

#### 8.3.1 Castings

**8.3.1.1 Radiographic Examination.** Body and bonnet or cover sections requiring radiography are as given below and as shown typically in Figs. 6 through 16. For body and bonnet configurations not represented, it is permissible to construct a composite coverage area based on these illustrations and the descriptions that follow. The distance  $A$  over which film coverage is required, is expressed in multiples of  $t_m$  where  $t_m$  is the minimum wall requirement as determined by para. 6.1. The value of  $A$  is intended to be greater of  $3t_m$  or 2.75 in. It should be recognized, however, that in some cases the specified value of  $A$  will exceed the intent of the film coverage area as illustrated in Figs. 6 through 16. For example, in Fig. 11 the body neck or run sections may not accommodate the full value

of  $A$  as defined. In such cases the requirement may be satisfied by providing film coverage substantially as shown in the sketches. Also, if the full defined coverage width  $A$  would result in the film running substantially into an adjacent fillet or crotch section, the value of  $A$  may be reduced to a practical maximum value. Small variations in coverage are permitted when necessary to accommodate standard film sizes. The radiographic procedures and acceptance standards to be used shall be in accordance with Annex B.

(a) *Body*

(1) a band around each weld end extending back from the body end a distance equal to the greater of  $3t_m$  or 2.75 in.;

(2) a band around the bonnet neck extending down from the top of body on pressure seal valves and from back of flange on bolted bonnet valves a distance equal to the greater of  $3t_m$  or 2.75 in.;

(3) a band in the area of the junction between each seat and body shell having a width equal to the greater of  $3t_m$  or 2.75 in. and an encompassing girth extending between the fillets of the intersecting sections, e.g., as shown approximately 210 deg for Fig. 6.

(b) *Bonnet*. The junction of the stuffing box with the bonnet closure plate or flange.

(c) *Cover*

(1) volumetric examination is not required for flat covers with or without raised faces;

(2) for dished covers, a band in the vicinity of the junction between the dished and flanged sections having a width equal to the greater of  $3t_m$  or 2.75 in.

**8.3.1.2 Surface Examination.** All exterior and accessible interior surfaces of body, bonnet, and cover castings shall be given a surface examination. Group 1 materials (Table 1) shall be given either a magnetic particle examination or a liquid penetrant examination. Groups 2 and 3 materials (Table 1) shall be given a liquid penetrant examination. Magnetic particle examinations shall be in accordance with the procedure and acceptance standards of Annex C. Liquid penetrant examinations shall be in accordance with the procedure and acceptance standards of Annex D.

**8.3.1.3 Ultrasonic Examination.** An ultrasonic examination of the casting in accordance with para. 8.3.2.1 may be substituted for the radiographic examination, provided that the user agrees and that it can be demonstrated that the ultrasonic examination produces interpretable results. The extent of coverage shall be as typically shown in Figs. 6 through 16.

### 8.3.2 Forgings, Bars, Plates, and Tubular Products

**8.3.2.1 Ultrasonic or Radiographic Examination.** The following sections shall be ultrasonically examined in accordance with procedure and acceptance standards in Annex E or radiographically examined in accordance with procedure and acceptance standards in Annex B.

(a) *Body* — cylindrical sections at run ends and body neck.

(b) *Bonnet* — ring section excluding stuffing box and yoke arms

(c) *Cover*

(1) volumetric examination is not required for flat covers with or without raised faces;

(2) for dished covers, a band in the vicinity of the junction between the dished and flanged sections having a width equal to the greater of  $3t_m$  or 2.75 in. If, during the examination, ultrasonic indications are noninterpretable due to grain size, the material shall be radiographed using the procedure requirements of para. 8.3.1.1. Subsurface linear indications exceeding 0.19 in. long in sections under 0.5 in. thick, 0.38 in. long in sections 0.5 to 1 in. thick, or 0.75 in. long in sections over 1 in. thick are unacceptable.

**8.3.2.2 Surface Examination.** All exterior and accessible interior surfaces of bodies, bonnets, and covers shall be given a surface examination. Group 1 materials (Table 1) shall be given either a magnetic particle examination or a liquid penetrant examination. Groups 2 and 3 materials (Table 1) shall be given a liquid penetrant examination. Magnetic particle examinations shall be in accordance with the procedure and acceptance standards of Annex C. Liquid penetrant examinations shall be in accordance with the procedure and acceptance standards of Annex D.

**8.3.3 Welded Fabrication.** Bodies and bonnets made by weld assembly of segments of castings, forgings, bars, tubular products, or plates, or combinations thereof, shall be examined, as applicable, by the methods of para. 8.3.1 for cast components, or para. 8.3.2 for forged, rolled, or wrought components. In addition, all fabrication welds shall receive nondestructive examination in accordance with the ASME Boiler and Pressure Vessel Code, Section VIII, Division 1, in a manner that results in a weld joint efficiency of 1.0. (These requirements are not applicable to welds such as for backseat bushings, seat rings, lifting lugs, and auxiliary connections.)

## 8.4 Defect Removal and Repair

**8.4.1 Defect Removal.** Defects in excess of acceptance standards shall be removed by suitable means. If removal of surface defects to an acceptable level does not result in reducing wall thickness below an acceptable value, the area shall be blended smoothly into surrounding surface.

**8.4.2 Repair by Welding.** Where defect removal results in a wall thickness below an acceptable value, resultant cavity may be repaired by welding, provided that all of the following requirements are satisfied.

(a) The welding procedure and welding operator are qualified in accordance with ASTM A 488 or the ASME Boiler and Pressure Vessel Code, Section IX.

(b) Weld repairs to fabrication welds are made in accordance with the ASME Boiler and Pressure Vessel Code, Section VIII, Division 1.

(c) Weld repairs are heat treated in accordance with the postweld heat treatment requirements of the ASME Boiler and Pressure Vessel Code, Section VIII, Division 1, Subsection C. The exemptions applicable to fabrica-

tion welds including groove, fillet, and circumferential butt welds also apply to repair welds. Postweld heat treatment (solution treatment) of repair welds in austenitic stainless steels is neither required nor prohibited except when required by the material specification.

(d) The repaired area is reexamined by the NDE method which originally disclosed the defect. The reexamination by magnetic particle or liquid penetrant methods of a repaired area originally disclosed by magnetic particle or liquid penetrant examination shall be performed after postweld heat treatment when postweld heat treatment is performed. The reexamination by radiography or ultrasonic methods of a repaired area originally disclosed by radiography or ultrasonic examination may be performed either before or after postweld heat treatment when postweld heat treatment is performed. The acceptance standards shall be as in the original examination.

(e) Weld repairs made as a result of radiographic examination shall be radiographed after welding. The acceptance standards for porosity and slag inclusion in welds shall be in accordance with the ASME Boiler and Pressure Vessel Code, Section VIII, Division 1, UW-51.

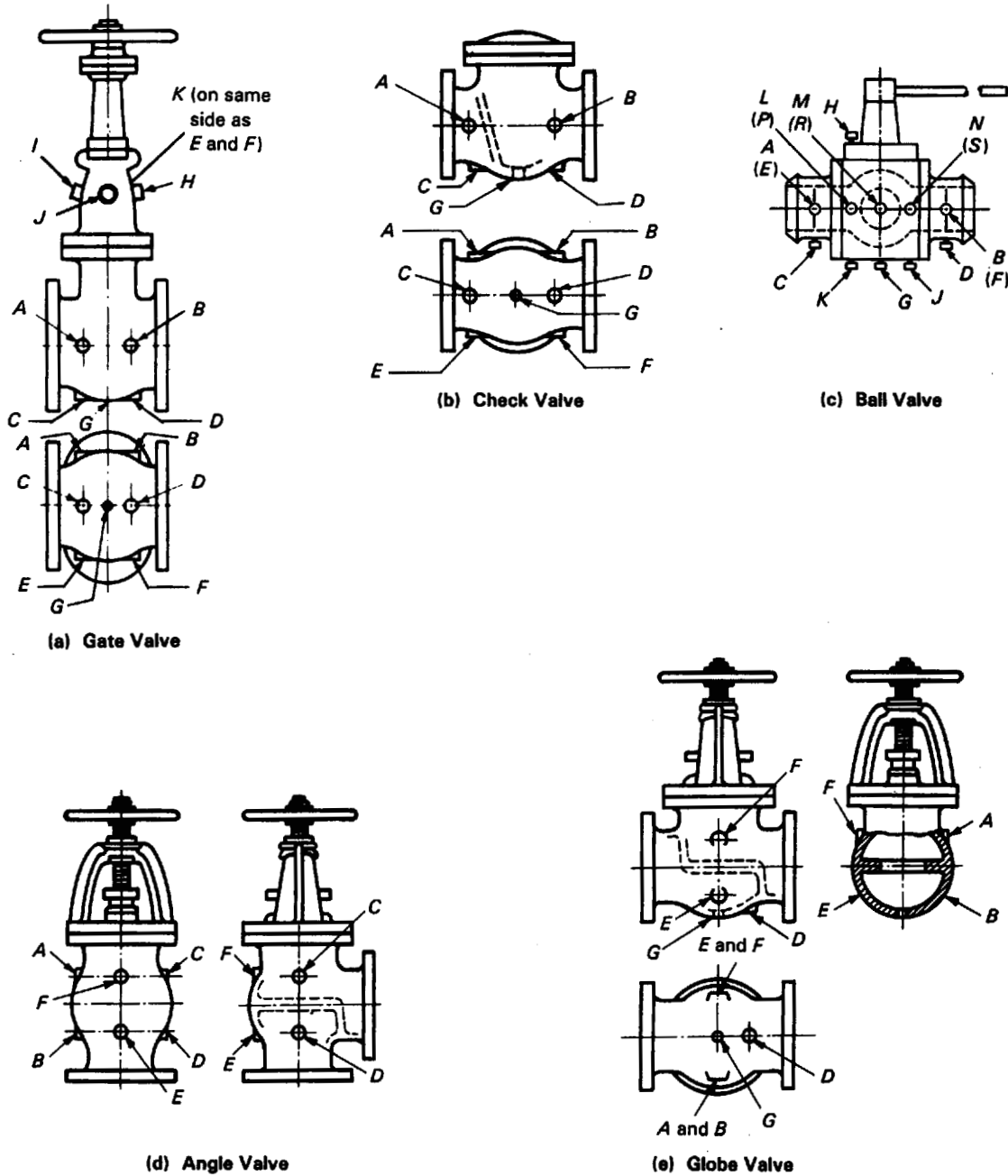

**GENERAL NOTE:**

The above sketches represent valves with symmetrical shapes. Sketches are illustrative only and do not imply design (see para. 6.3.7)

**FIG. 1 METHOD OF DESIGNATING LOCATION OF AUXILIARY CONNECTIONS WHEN SPECIFIED**

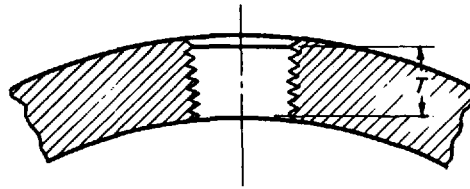

Conn. Size, NPS	3/8	1/2	3/4	1	1 1/4	1 1/2	2
Length of Thread, <i>T</i> , in. [Note (1)]	0.41	0.53	0.55	0.68	0.71	0.72	0.76

**NOTE:**

(1) In no case shall the effective length of thread, *T*, be less than that shown in table above. These lengths are equal to the effective thread length of American National Standard External Pipe Threads (ANSI/ASME B.1.20.1).

**FIG. 2 THREAD LENGTH FOR AUXILIARY CONNECTIONS**  
 (See Para. 6.3.2)

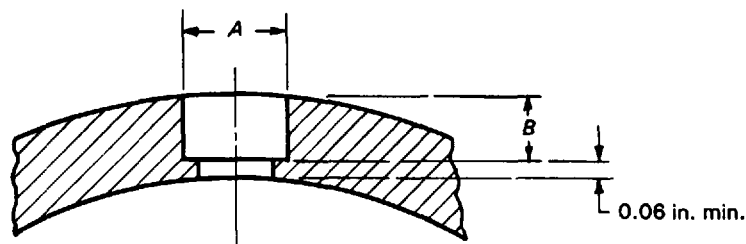

Conn. Size, NPS	3/8	1/2	3/4	1	1 1/4	1 1/2	2
Min. Diam. of Socket <i>A</i> , in.	0.690	0.855	1.065	1.330	1.675	1.915	2.406
Min. depth of socket <i>B</i> , in.	0.19	0.19	0.25	0.25	0.25	0.25	0.31

**FIG. 3 SOCKET WELDING FOR AUXILIARY CONNECTIONS**  
 (See Para. 6.3.3)

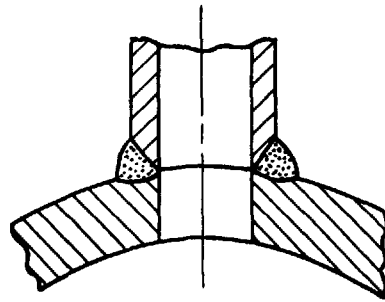

**FIG. 4 BUTT WELDING FOR AUXILIARY CONNECTIONS**  
(See Para. 6.3.4)

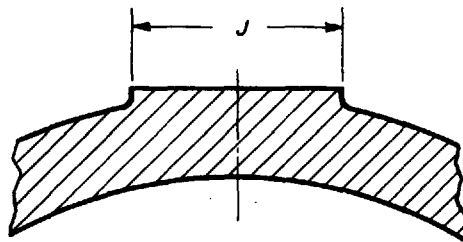

Conn. Size, NPS	3/8	1/2	3/4	1	1 1/4	1 1/2	2
Diam. of Boss <i>J</i> , in.	1.25	1.50	1.75	2.12	2.50	2.75	3.38

**FIG. 5 BOSSES FOR AUXILIARY CONNECTIONS**  
(See Para. 6.3.5)

TYPICAL CASTING SECTIONS SHOWING REQUIRED  
 RADIOGRAPHIC EXAMINATION

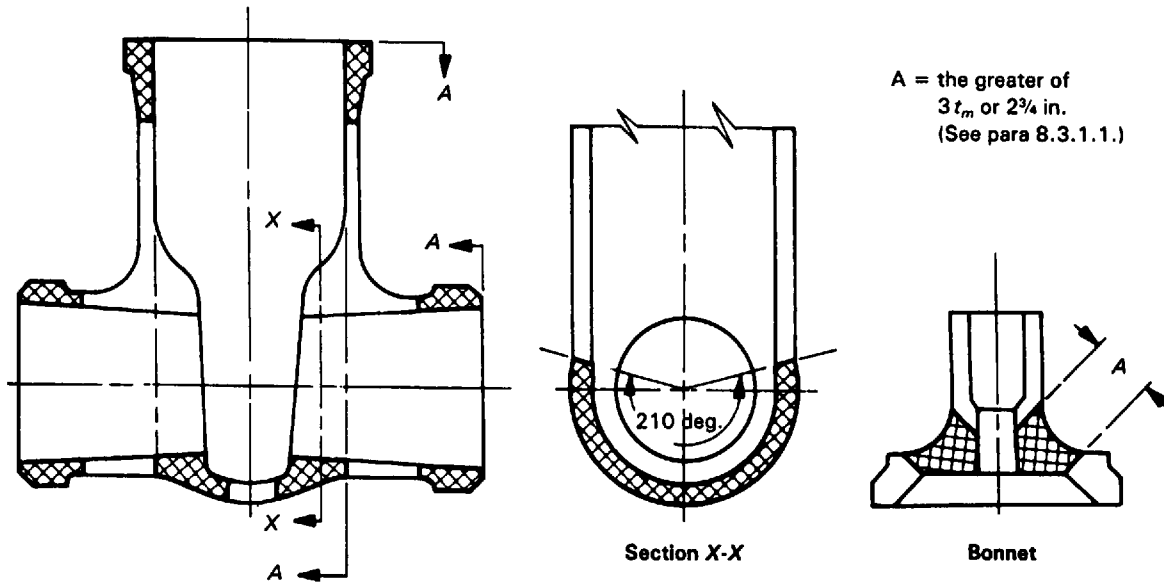

FIG. 6 GATE BODY (PRESSURE SEAL BONNET)

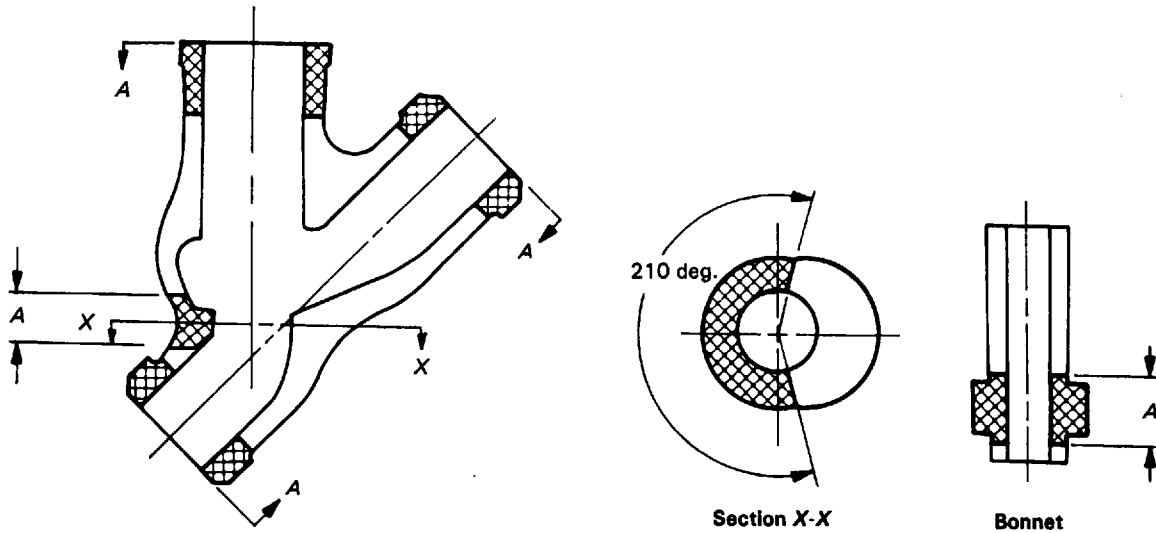
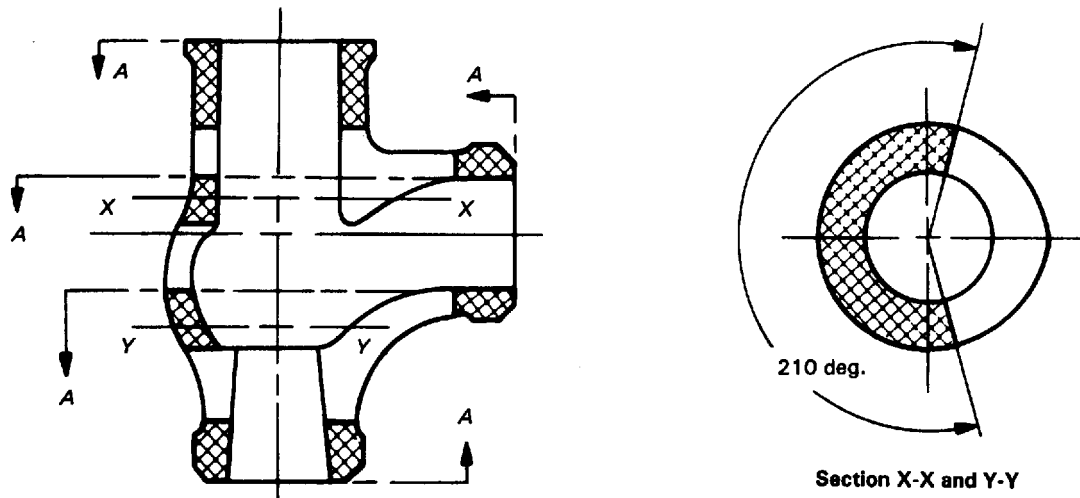

FIG. 7 Y PATTERN GLOBE BODY (PRESSURE SEAL BONNET)



ASME B16.34-1996

VALVES — FLANGED,  
THREADED, AND WELDING END



**FIG. 8 ANGLE BODY (PRESSURE SEAL BONNET)**  
Bonnet Same As Y Pattern Globe

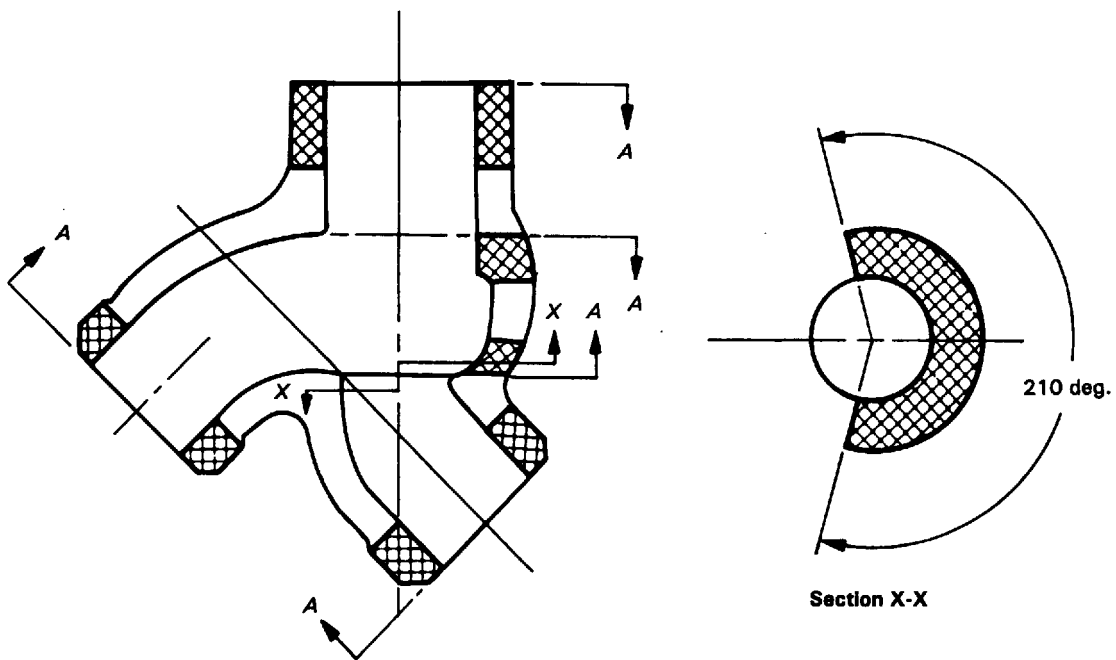

**FIG. 9 ELBOW DOWN (PRESSURE SEAL BONNET)**

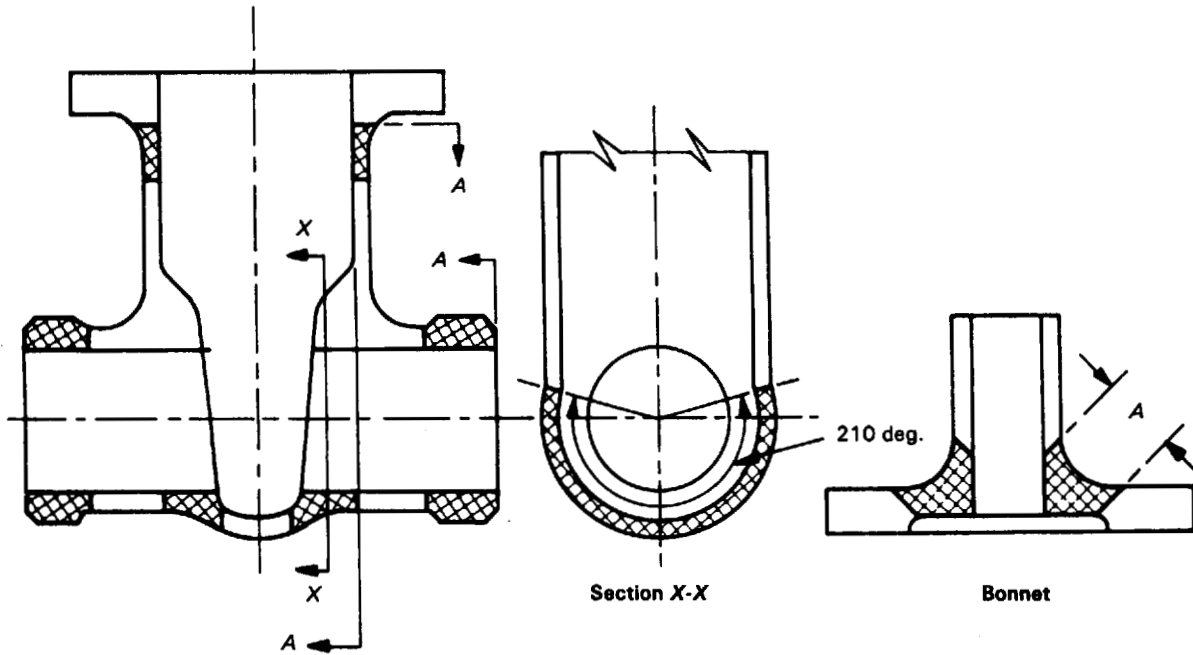

FIG. 10 GATE BODY (FLANGED BONNET)

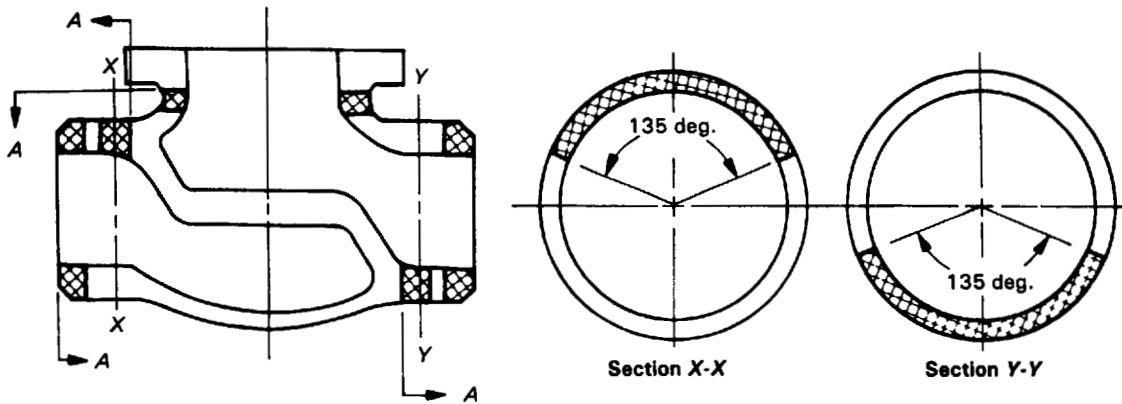

FIG. 11 GLOBE BODY (FLANGED BONNET)

ASME B16.34-1996

VALVES — FLANGED,  
THREADED, AND WELDING END

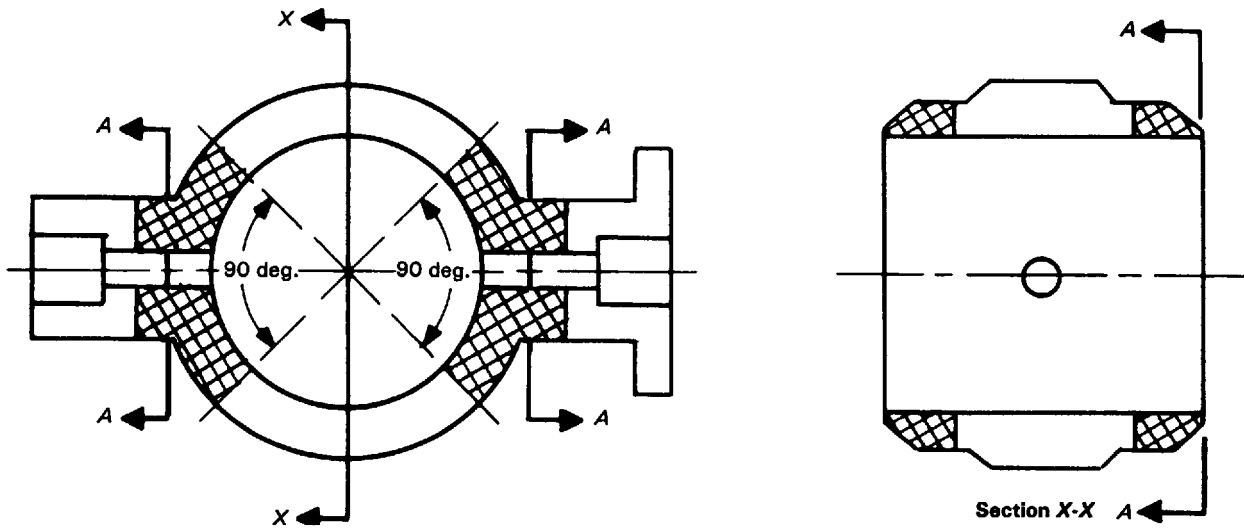

FIG. 12 BUTTERFLY BODY

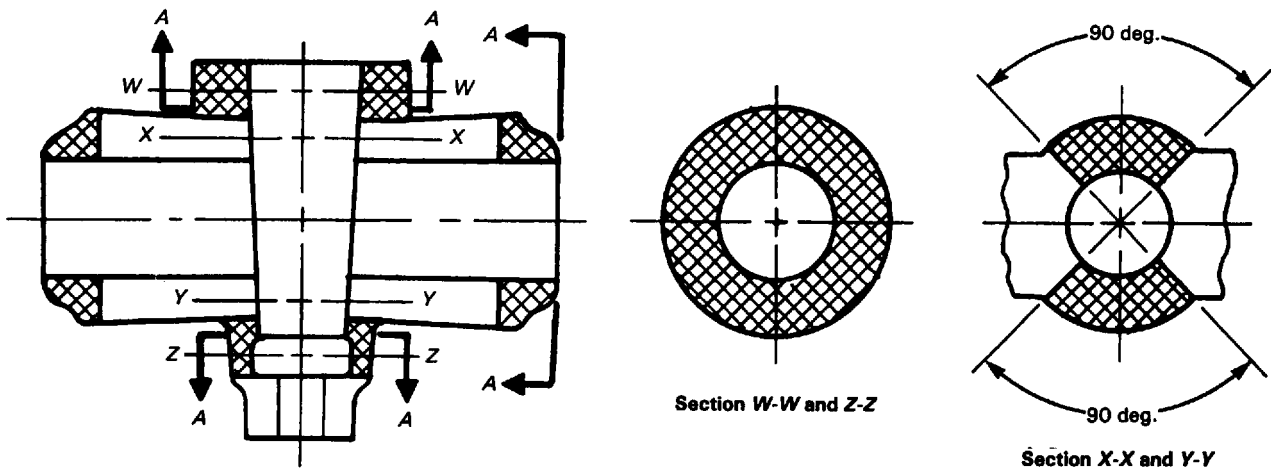

FIG. 13 PLUG BODY

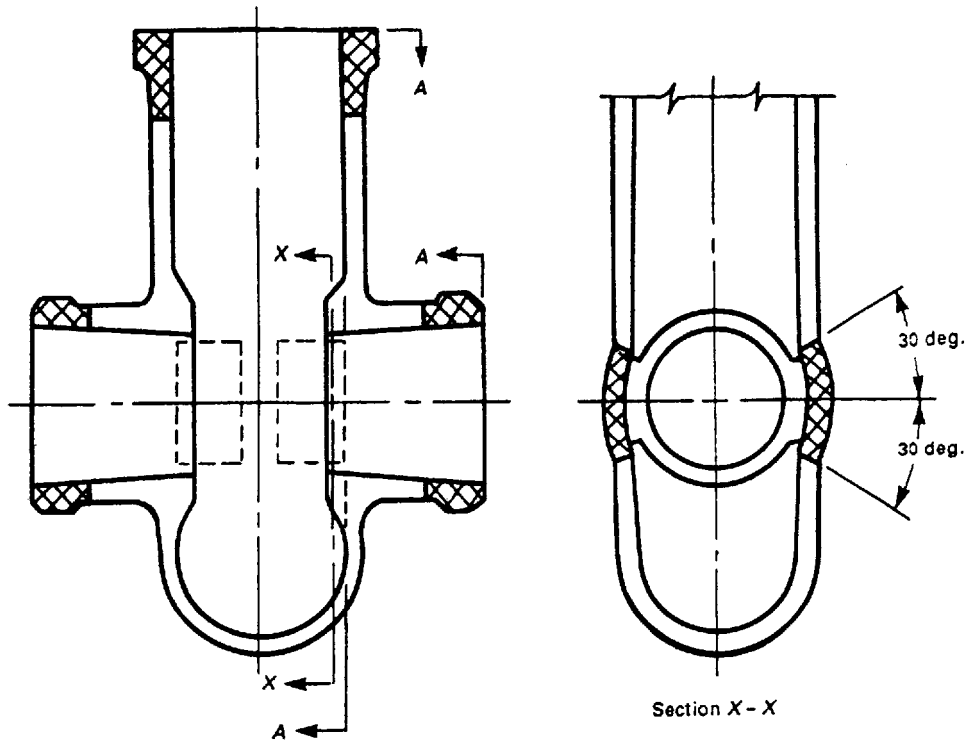

FIG. 14 CONDUIT GATE BODY (PRESSURE SEAL BONNET)

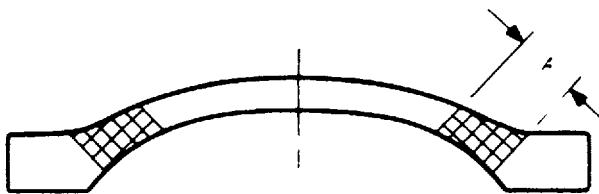
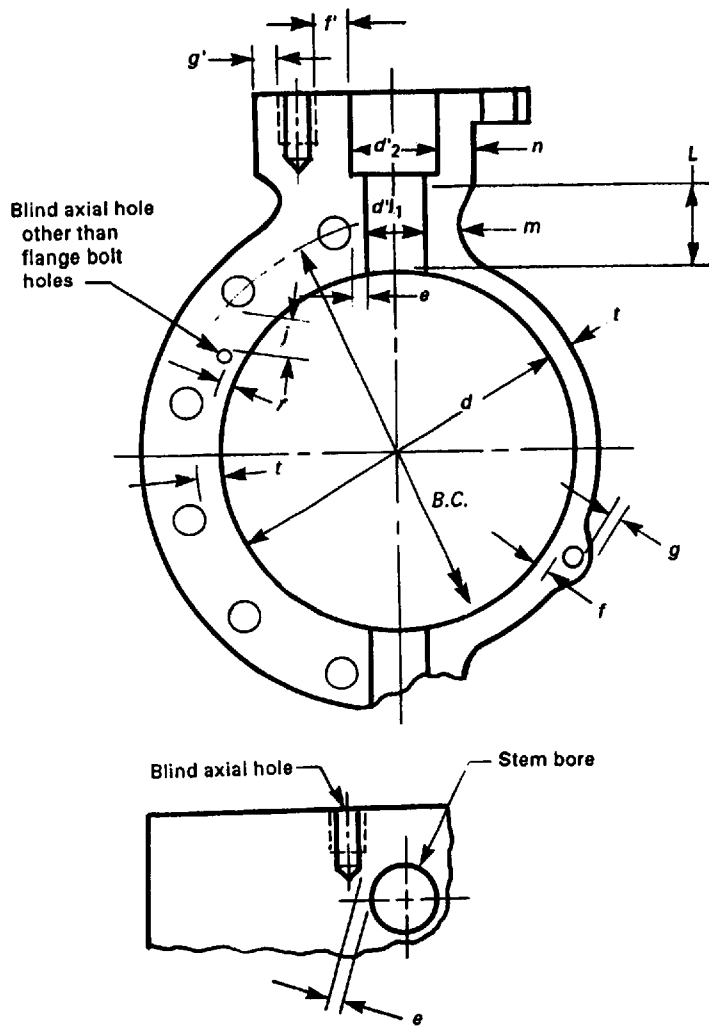

FIG. 15 DISHED COVER



FIG. 16 FLAT COVER



Relationship	Reference
$t \geq t_m$	6.1.1 [Note (2)]
$m \geq t'_1$	6.1.3(b) [Note (2)]
$n \geq t'_2$	6.1.3(b) [Notes (2) and (3)]
$L \geq t_m (1 + 1.1 \sqrt{d/t_m})$	6.1.3(b)
$f \geq 0.25 t_m$ [Note (1)]	6.7(e)
$f + g \geq t_m$	6.7(e)
$f' \geq 0.25 t'_2$ [Note (1)]	6.1.3(c)
$f' + g' \geq t'_2$	6.1.3(c)
$c \geq 0.75 t_m$	6.7(g)
$j \geq 0.25 t_m$ [Note (1)]	6.7(f)
$e \geq 0.25 t'_1$ [Note (1)]	6.7(d)

**NOTES:**

- (1) In no case less than 0.1 in.
- (2) Except where para. 6.1.6 applies.
- (3) If  $d'2$  is located outside of the stem seal, i.e., beyond the internal wetted perimeter, the minimum thickness requirements shall be determined by the manufacturer.

(a)

**FIG. 17 BUTTERFLY VALVE BODY**

VALVES – FLANGED,  
THREADED, AND WELDING END

ASME B16.34a-1998

**TABLE 1 MATERIAL SPECIFICATION LIST**  
Applicable ASTM Specification

(a)

Group No.	Material Nominal Designation	Product Form											
		Forgings		Castings		Plates		Bars		Tubular			
		Spec. No.	Grade	Spec. No.	Grade	Spec. No.	Grade	Spec. No.	Grade	Spec. No.	Grade		
1.1	C												
	C-Si	A 105	LF2	A 216	WCB	A 515	70	A 675	70	A 672	B 70		
	C-Mn-Si	A 350	LF2			A 516	70	A 105	LF2	A 672	C 70		
	C-Mn-Si-V	A 350	LF6 Cl.1			A 537	Cl. 1	A 350	C	A 672			
1.2	C-Si												
	2 1/2 Ni	A 350	LF3	A 352	LC2	A 203	B	A 350	LF3	A 106	C		
	3 1/2 Ni			A 352	LC3	A 203	E						
	C-Mn-Si	A 350	LF6 Cl.2	A 216	WCC								
1.3	C												
	C-Si	A 350	LF1	A 352	LCB	A 515	65	A 675	65	A 672	B 65		
	2 1/2 Ni					A 203	A						
	3 1/2 Ni					A 203	D						
1.4	C												
	C-Si	A 350	LF1			A 516	65	A 675	60	A 106	B		
	C-Mn-Si									A 672	B 60		
										A 672	C 60		
1.5	C-1/2Mo	A 182	F1	A 217	WC1	A 204	A	A 182	F1	A 691	CM-70		
				A 352	LC1	A 204	B						
1.6	C-1/2Mo												
	1/2Cr-1/2Mo					A 387	2 Cl. 1			A 335	P1		
	1Cr-1/2Mo					A 387	2 Cl. 2			A 369	FP1		
1.7	C-1/2Mo					A 387	12 Cl. 1			A 691	1/2CR		
	1/2Cr-1/2Mo												
	Ni-1/2Cr-1/2Mo												
	3/4Ni-Mo-3/4Cr	A 182	F2	A 217	WC4	A 204	C	A 182	F2	A 691	CM-75		

(Notes follow at end of table)

(Table 1 continues on the next page)

**TABLE 1 MATERIAL SPECIFICATION LIST (CONT'D)**  
Applicable ASTM Specification

**GROUP 1 MATERIALS (CONT'D)**

Material		Product Form									
Group No.	Nominal Designation	Forgings		Castings		Plates		Bars		Tubular	
		Spec. No.	Grade	Spec. No.	Grade	Spec. No.	Grade	Spec. No.	Grade	Spec. No.	Grade
1.8	1Cr-1/2Mo					A 387	12 Cl. 2			A 691	1CR
	1 1/4Cr-1/2Mo-Si					A 387	11 Cl. 1			A 335	P12
	2 1/4Cr-1Mo					A 387	22 Cl. 1			A 369	FP12
1.9	1 Cr-1/2Mo	A 182	F12 Cl. 2							A 691	1 1/4CR
	1 1/4Cr-1/2Mo-Si	A 182	F11 Cl. 2							A 335	P11
	1 1/4Cr-1/2Mo			A 217	WC6					A 369	FP11
1.10	2 1/4Cr-1Mo	A 182	F22 Cl. 3			A 387	22 Cl. 2			A 691	2 1/4CR
				A 217	WC9					A 335	P22
1.11	3Cr-1Mo										
	Mn-1/2Mo	A 182	F21			A 387	21 Cl. 2			A 182	F21
	Mn-s1/2Mo-1/2Ni					A 302	A & B				
	Mn-1/2Mo-3/4Ni					A 302	C				
	C-Mn-Si					A 302	D				
1.12	5Cr-1/2Mo					A 537	CL2				
						A 387	5 Cl. 1			A 691	5CR
1.13	5Cr-1/2Mo-Si					A 387	5 Cl. 2			A 335	P5
	5Cr-1/2Mo	A 182	F5a							A 369	FP5
1.14	9Cr-1Mo	A 182	F5	A 217	C5					A 335	P5b
		A 182	F9								
1.15	9Cr-1Mo-V	A 182	F91	A 217	C12					A 182	F9
		A 182	F91	A 217	C12A	A 387	91 Cl.2			A 182	F91

(a)

VALVES – FLANGED,  
THREADED, AND WELDING END

ASME B16.34a-1998

**TABLE 1 MATERIAL SPECIFICATION LIST**  
Applicable ASTM Specification

(a)

GROUP 2 MATERIALS		Product Form												
		Material		Forgings		Castings		Plates		Bars		Tubular		
Group No.	Nominal Designation	Spec. No.	Grade	Spec. No.	Grade	Spec. No.	Grade	Spec. No.	Grade	Spec. No.	Grade	Spec. No.	Grade	
2.1	18Cr-8Ni	A 182	F304	A 351	CF3	A 240	304	A 182	F304	A 312	TP304	A 312	TP304H	
		A 182	F304H	A 351	CF8	A 240	304H	A 182	F304H	A 312	TP304H	A 358	304	
2.2	16Cr-12Ni-2Mo	A 182	F316			A 240	316	A 182	F316	A 312	TP316	A 312	TP316H	
		A 182	F316H			A 240	316H	A 182	F316H	A 358	316	A 376	TP316	
2.3	18Cr-8Ni 18Cr-13Ni-3Mo 16Cr-12Ni-2Mo 19Cr-10Ni-3Mo			A 351	CF3A									
				A 351	CF8A									
				A 351	CF3M									
				A 351	CF8M									
2.4	18Cr-10Ni-Ti	A 182	F304L			A 240	304L	A 182	F304L	A 312	TP304L	A 312	TP304L	
		A 182	F316L			A 240	316L	A 182	F316L	A 312	TP316L	A 312	TP316L	
2.4	18Cr-10Ni-Ti	A 182	F321			A 240	321	A 182	F321	A 312	TP321	A 312	TP321H	
		A 182	F321H			A 240	321H	A 182	F321H	A 358	321	A 376	TP321H	
				A 351	CG8M			A 182	F316L	A 430	FP316	A 430	FP316H	
								A 479	316L					

(Notes follow at end of table)

(Table 1 continues on the next page)



**TABLE 1 MATERIAL SPECIFICATION LIST (CONT'D)**  
Applicable ASTM Specification

**(a) GROUP 2 MATERIALS (CONT'D)**

Material		Product Form									
Group No.	Nominal Designation	Forgings		Castings		Plates		Bars		Tubular	
		Spec. No.	Grade	Spec. No.	Grade	Spec. No.	Grade	Spec. No.	Grade	Spec. No.	Grade
2.5	18Cr-10Ni-Cb	A 182	F347	A 351	CF8C	A 240	347	A 182	F347	A 312	TP347
		A 182	F347H			A 240	347H		A 312		TP347H
		A 182	F348			A 240	348		A 358		TP347
		A 182	F348H			A 240	348H		A 376		TP347
2.6	25Cr-12Ni 23Cr-12Ni			A 351	CH8 CH20			A 479	347H	A 430	FP347
						A 240	309S		A 312		TP348
2.7	25Cr-20Ni	A 182	F310H	A 351	CK20	A 240	310S	A 182	F310H	A 312	TP310H
						A 240	310H		A 358		310H
2.8	20Cr-18Ni-6Mo 22Cr-5Ni-3Mo-N 25Cr-7Ni-4Mo-N 24Cr-10Ni-4Mo-V 25Cr-5Ni-2Mo-2Cu 25Cr-7Ni-3.5Mo-W-Cb 25Cr-7Ni-3.5Mo-N-Cu-W	A 182	F44	A 351	CK3MCuN	A 240	S31254	A 479	S31254	A 312	S31254
		A 182	F51			A 240	S31803		A 358		S31254
		A 182	F53			A 240	S32750		A 789		S31803
						A 240	S32750		A 790		S31803
						A 240	S32750		A 789		S32750
		A 182	Gr. F55	A 351	Gr. CE8MN Gr. CD4MCu Gr. CD3MWCuN	A 240	Gr. S32760	A 479	S32750	A 790	S32750
				A 351		A 240	Gr. S32760	A 789	S32760	A 790	S32760

VALVES — FLANGED,  
THREADED, AND WELDING END

ASME B16.34a-1998

**TABLE 1 MATERIAL SPECIFICATION LIST**  
Applicable ASTM Specification

GROUP 3 MATERIALS		Product Form											
		Material		Forgings		Castings		Plates		Bars		Tubular	
Group No.	Nominal Designation	Spec. No.	Grade	Spec. No.	Grade	Spec. No.	Grade	Spec. No.	Grade	Spec. No.	Grade	Spec. No.	Grade
3.1	35Ni-35Fe-20Cr-Cb	B 462	N08020			B 463	N08020	B 473	N08020	B 464	N08020	B 468	N08020
3.2	99Ni	B 160	N02200			B 162	N02200	B 160	N02200	B 161	N02200	B 163	N02200
3.3	99Ni-Low C	B 160	N02201			B 162	N02201	B 160	N02201				
3.4	67Ni-30Cu	B 564	N04400			B 127	N04400	B 164	N04400	B 165	N04400	B 163	N04400
		B 164	N04405					B 164	N04405				
3.5	72Ni-15Cr-8Fe	B 564	N06600			B 168	N06600	B 166	N06600	B 167	N06600	B 163	N06600
3.6	33Ni-42Fe-21Cr	B 564	N08800			B 409	N08800	B 408	N08800	B 163	N08800		
3.7	65Ni-28Mo-2Fe	B 335	N10665			B 333	N10665	B335	N10665	B 622	N10665		
3.8	54Ni-16Mo-15Cr 60Ni-22Cr-9Mo-3.5Cb 62Ni-28Mo-5Fe 70Ni-16Mo-7Cr-5Fe 61Ni-16Mo-16Cr 42Ni-21.5Cr-3Mo-2.3Cu	B 564	N10276			B 575	N10276	B 574	N10276	B 622	N10276		
		B 564	N06625			B 443	N06625	B 446	N06625	B 622	N10001		
		B 335	N10001			B 333	N10001	B 335	N10001	B 622	N10001		
		B 573	N10003			B 434	N10003	B 573	N10003	B 622	N10003		
		B 574	N06455			B 575	N06455	B 574	N06455	B 622	N06455		
		B 425	N08825			B 424	N08825	B 425	N08825	B 423	N08825		

(Notes follow at end of table)

(Table 1 continues on the next page)

(a)

**TABLE 1 MATERIAL SPECIFICATION LIST (CONT'D)**  
**Applicable ASTM Specification**

**GROUP 3 MATERIALS (CONT'D)**

Material		Product Form											
		Forgings		Castings		Plates		Bars		Tubular			
Group No.	Nominal Designation	Spec. No.	Grade	Spec. No.	Grade	Spec. No.	Grade	Spec. No.	Grade	Spec. No.	Grade	Spec. No.	Grade
3.9	47Ni-22Cr-9Mo-18Fe	B 572	N06002			B 435	N06002	B 572	N06002	B 622	N06002		
3.10	25Ni-47Fe-21Cr-5Mo	B 672	N08700			B 599	N08700	B 672	N08700				
3.11	44Fe-25Ni-21Cr-Mo	B 649	N08904			B 625	N08904	B 649	N08904	B 677	N08904		
3.12	26Ni-43Fe-22Cr-5Mo 47Ni-22Cr-20Fe-7Mo	B 621 B 581	N08320 N06985			B 620 B 582	N08320 N06985	B 621 B 581	N08320 N06985	B 622 B 622	N08320 N06985		
3.13	49Ni-25Cr-18Fe-6Mo Ni-Fe-Cr-Mo-Cu-Low C	B 581 B 564	N06975 N08031			B 582 B 625	N06975 N08031	B 581 B 649	N06975 N08031	B 622 B 622	N06975 N08031		
3.14	47Ni-22Cr-19Fe-6Mo	B 581	N06007			B 582	N06007	B 581	N06007	B 622	N06007		
3.15	33Ni-2Fe-21Cr Ni-Mo Ni-Mo-Cr	B 564	N08810			A 494 A 494	N-12MV CW-12MW	B 408	N08810	B 407	N08810		
3.16	35Ni-19Cr-1/4Si	B 511	N08330			B 536	N08330	B 511	N08330	B 535	N08330		
3.17	29Ni-20.5Cr-3.5Cu-2.5Mo					A 351	CN-7M						

(a)

**TABLE 1 MATERIAL SPECIFICATION LIST (CONT'D)**  
**Applicable ASTM Specification**

Group 4 Materials					
Bolting Material Specifications [Note (1)]					
Specification No.	Grade	Notes	Specification No.	Grade	Notes
A 193		(2)(3)	A 449		(7)(8)
A 307 B		(4)(5)	A 453		(9)(10)
A 320		(2)(3)(6)	A 540		
A 354			A 564	630	(7)
B 164		(11)(12)(13)	B 408		(11)(12)(13)
B 166		(11)(12)	B 473		(11)
B 335	N10665	(11)	B 574	N10276	(11)
			B 574	N06022	(11)
			B 637	N07718	(11)

**GENERAL NOTES:**

- (a) The user is responsible for assuring that bolting material is not used beyond limits specified in the governing codes or regulations.
- (b) ASME Boiler and Pressure Vessel Code Section II materials that also meet the requirements of the listed ASTM specification may also be used.
- (c) Material limitations, restrictions, and special requirements are shown on pressure-temperature tables, Tables 2.

**NOTES:**

- (1) Repair welding of bolting material is not permitted.
- (2) Where austenitic bolting materials have been carbide solution treated but not strain hardened, they are designated Class 1 or Class 1A in ASTM A 193. ASTM A 194 nuts of corresponding material are recommended.
- (3) Where austenitic bolting materials have been carbide solution treated and strain hardened, they are designated Class 2 in ASTM A 193. ASTM A 194 nuts of corresponding material are recommended.
- (4) For limitations of usage and strength level, see para. 5.1.1.
- (5) Bolts with drilled or undersize heads shall not be used.
- (6) For ferritic bolting materials intended for service at low temperatures, ASTM A 194 Grade 4 or Grade 7 nuts are recommended.
- (7) Acceptable nuts for use with these quenched and tempered steel bolts are ASTM A 194 Grade 2 and 2H.
- (8) Mechanical property requirements for studs shall be the same as those for bolts.
- (9) These are bolting materials suitable for high temperature service with austenitic stainless steel valve materials.
- (10) Only Grades 651 and 660 shall be used.
- (11) Nuts may be of the same material or may be of compatible grade of ASTM A 194.
- (12) Forging quality not permitted unless the producer last heating or working these parts tests them as required for other permitted conditions in the same specification and certifies their final tensile, yield, and elongation properties to equal or exceed the requirements for one of the other permitted conditions.
- (13) Maximum operating temperature is arbitrarily set at 500°F, unless material has been annealed, solution annealed, or hot finished, because hard temper adversely affects design stress in the creep-rupture temper range.

VALVES — FLANGED  
THREADED, AND WELDING END

ASME B16.34-1996

## PRESSURE-TEMPERATURE RATINGS

For definition of Standard and Special Classes, see paras. 2.1.1 and 2.1.2. Tables 2 follow  
on pp. 33 – 87.

NOTE: All pressures are given as gage pressure.

VALVES — FLANGED,  
THREADED, AND WELDING END

ASME B16.34a-1998

**TABLE 2-1.1**  
**RATINGS FOR GROUP 1.1 MATERIALS**

(a)

A 105 (1)(6)	A 515 Gr. 70 (1)	A 675 Gr. 70 (1)(4)(5)	A 672 Gr. B70 (1)
A 216 Gr. WCB (1)	A 516 Gr. 70 (1)(2)	A 696 Gr. C	A 672 Gr. C70 (1)
A 350 Gr. LF2 (1)	A 537 Cl. 1 (3)	A 350 Gr. LF6 Cl.1 (7)	

NOTES:

- (1) Upon prolonged exposure to temperatures above 800°F, the carbide phase of steel may be converted to graphite. Permissible, but not recommended for prolonged use above 800°F.
- (2) Not to be used over 850°F.
- (3) Not to be used over 700°F.
- (4) Leaded grades shall not be used where welded or in any application above 500°F.
- (5) For service temperatures above 850°F, it is recommended that killed steels containing not less than 0.10% residual silicon be used.
- (6) Only killed steel shall be used above 850°F.
- (7) Not to be used over 500°F.

**TABLE 2-1.1A STANDARD CLASS**

Temperature, °F	Working Pressures by Classes, psig							
	150	300	400	600	900	1500	2500	4500
-20 to 100	285	740	990	1,480	2,220	3,705	6,170	11,110
200	260	675	900	1,350	2,025	3,375	5,625	10,120
300	230	655	875	1,315	1,970	3,280	5,470	9,845
400	200	635	845	1,270	1,900	3,170	5,280	9,505
500	170	600	800	1,200	1,795	2,995	4,990	8,980
600	140	550	730	1,095	1,640	2,735	4,560	8,210
650	125	535	715	1,075	1,610	2,685	4,475	8,055
700	110	535	710	1,065	1,600	2,665	4,440	7,990
750	95	505	670	1,010	1,510	2,520	4,200	7,560
800	80	410	550	825	1,235	2,060	3,430	6,170
850	65	270	355	535	805	1,340	2,230	4,010
900	50	170	230	345	515	860	1,430	2,570
950	35	105	140	205	310	515	860	1,545
1000	20	50	70	105	155	260	430	770

**TABLE 2-1.1B SPECIAL CLASS**

Temperature, °F	Working Pressures by Classes, psig							
	150	300	400	600	900	1500	2500	4500
-20 to 100	290	750	1,000	1,500	2,250	3,750	6,250	11,250
200	290	750	1,000	1,500	2,250	3,750	6,250	11,250
300	290	750	1,000	1,500	2,250	3,750	6,250	11,250
400	290	750	1,000	1,500	2,250	3,750	6,250	11,250
500	290	750	1,000	1,500	2,250	3,750	6,250	11,250
600	275	715	950	1,425	2,140	3,565	5,940	10,690
650	270	700	935	1,400	2,100	3,495	5,825	10,485
700	265	695	925	1,390	2,080	3,470	5,780	10,405
750	240	630	840	1,260	1,890	3,150	5,250	9,450
800	200	515	685	1,030	1,545	2,570	4,285	7,715
850	130	335	445	670	1,005	1,670	2,785	5,015
900	85	215	285	430	645	1,070	1,785	3,215
950	50	130	170	260	385	645	1,070	1,930
1000	25	65	85	130	195	320	535	965

(a)

**TABLE 2-1.2  
RATINGS FOR GROUP 1.2 MATERIALS**

A 106 Gr. C (3)	A 203 Gr. E (1)	A 350 Gr. LF3 (2)	A 352 Gr. LC3 (2)
A 203 Gr. B (1)	A 216 Gr. WCC (1)	A 352 Gr. LC2 (2)	A 352 Gr. LCC (2)
A 350 Gr. LF6 Cl.2 (4)			

**NOTES:**

- (1) Upon prolonged exposure to temperatures above 800°F, the carbide phase of steel may be converted to graphite. Permissible, but not recommended for prolonged use above 800°F.
- (2) Not to be used over 650°F.
- (3) Not to be used over 800°F.
- (4) Not to be used over 500°F.

**TABLE 2-1.2A STANDARD CLASS**

Temperature, °F	Working Pressures by Classes, psig							
	150	300	400	600	900	1500	2500	4500
-20 to 100	290	750	1,000	1,500	2,250	3,750	6,250	11,250
200	260	750	1,000	1,500	2,250	3,750	6,250	11,250
300	230	730	970	1,455	2,185	3,640	6,070	10,925
400	200	705	940	1,410	2,115	3,530	5,880	10,585
500	170	665	885	1,330	1,995	3,325	5,540	9,965
600	140	605	805	1,210	1,815	3,025	5,040	9,070
650	125	590	785	1,175	1,765	2,940	4,905	8,825
700	110	570	755	1,135	1,705	2,840	4,730	8,515
750	95	505	670	1,010	1,510	2,520	4,200	7,560
800	80	410	550	825	1,235	2,060	3,430	6,170
850	65	270	355	535	805	1,340	2,230	4,010
900	50	170	230	345	515	860	1,430	2,570
950	35	105	140	205	310	515	860	1,545
1000	20	50	70	105	155	260	430	770

**TABLE 2-1.2B SPECIAL CLASS**

Temperature, °F	Working Pressures by Classes, psig							
	150	300	400	600	900	1500	2500	4500
-20 to 100	290	750	1,000	1,500	2,250	3,750	6,250	11,250
200	290	750	1,000	1,500	2,250	3,750	6,250	11,250
300	290	750	1,000	1,500	2,250	3,750	6,250	11,250
400	290	750	1,000	1,500	2,250	3,750	6,250	11,250
500	290	750	1,000	1,500	2,250	3,750	6,250	11,250
600	290	750	1,000	1,500	2,250	3,750	6,250	11,250
650	290	750	1,000	1,500	2,250	3,750	6,250	11,250
700	275	710	950	1,425	2,135	3,560	5,930	10,670
750	240	630	840	1,260	1,890	3,150	5,250	9,450
800	195	515	685	1,030	1,545	2,570	4,285	7,715
850	130	335	445	670	1,005	1,670	2,785	5,015
900	80	215	285	430	645	1,070	1,785	3,215
950	50	130	170	260	385	645	1,070	1,930
1000	25	65	85	130	195	320	535	965

VALVES — FLANGED,  
THREADED, AND WELDING END

ASME B16.34a-1998

**TABLE 2-1.3  
RATINGS FOR GROUP 1.3 MATERIALS**

A 203 Gr. A (1)	A 352 Gr. LCB (5)	A 516 Gr. 65 (1)(2)	A 672 Gr. B65 (1)
A 203 Gr. D (1)	A 515 Gr. 65 (1)	A 675 Gr. 65 (1)(3)(4)	A 672 Gr. C65 (1)

**NOTES:**

- (1) Upon prolonged exposure to temperatures above 800°F, the carbide phase of steel may be converted to graphite. Permissible, but not recommended for prolonged use above 800°F.
- (2) Not to be used over 850°F.
- (3) Leaded grades shall not be used where welded or in any application above 500°F.
- (4) For service temperatures above 850°F, it is recommended that killed steel containing not less than 0.10% residual silicon be used.
- (5) Not to be used over 650°F.

**TABLE 2-1.3A STANDARD CLASS**

Temperature, °F	Working Pressures by Classes, psig							
	150	300	400	600	900	1500	2500	4500
-20 to 100	265	695	925	1,390	2,085	3,470	5,785	10,415
200	250	655	875	1,315	1,970	3,280	5,470	9,845
300	230	640	850	1,275	1,915	3,190	5,315	9,565
400	200	620	825	1,235	1,850	3,085	5,145	9,260
500	170	585	775	1,165	1,745	2,910	4,850	8,735
600	140	535	710	1,065	1,600	2,665	4,440	7,990
650	125	525	695	1,045	1,570	2,615	4,355	7,840
700	110	520	690	1,035	1,555	2,590	4,320	7,775
750	95	475	630	945	1,420	2,365	3,945	7,100
800	80	390	520	780	1,175	1,955	3,260	5,865
850	65	270	355	535	805	1,340	2,230	4,010
900	50	170	230	345	515	860	1,430	2,570
950	35	105	140	205	310	515	860	1,545
1000	20	50	70	105	155	260	430	770

**TABLE 2-1.3B SPECIAL CLASS**

Temperature, °F	Working Pressures by Classes, psig							
	150	300	400	600	900	1500	2500	4500
-20 to 100	265	695	925	1,390	2,085	3,470	5,785	10,415
200	265	695	925	1,390	2,085	3,470	5,785	10,415
300	265	695	925	1,390	2,085	3,470	5,785	10,415
400	265	695	925	1,390	2,085	3,470	5,785	10,415
500	265	695	925	1,390	2,085	3,470	5,785	10,415
600	265	695	925	1,390	2,085	3,470	5,780	10,405
650	260	680	910	1,360	2,040	3,400	5,670	10,205
700	255	665	885	1,330	1,995	3,320	5,535	9,965
750	225	590	790	1,185	1,775	2,960	4,930	8,870
800	190	490	650	980	1,465	2,445	4,070	7,330
850	130	335	445	670	1,005	1,670	2,785	5,015
900	85	215	285	430	645	1,070	1,785	3,215
950	50	130	170	260	385	645	1,070	1,930
1000	25	65	85	130	195	320	535	965



**TABLE 2-1.4**  
**RATINGS FOR GROUP 1.4 MATERIALS**

A 106 Gr. B (1)	A 515 Gr. 60 (1)(2)	A 675 Gr. 60 (1)(2)(3)	A 672 Gr. B60 (1)
A 350 Gr. LF1 (1)	A 516 Gr. 60 (1)(2)	A 696 Gr. B	A 672 Gr. C60 (1)

**NOTES:**

- (1) Upon prolonged exposure to temperatures above 800°F, the carbide phase of steel may be converted to graphite. Permissible, but not recommended for prolonged use above 800°F.
- (2) Not to be used over 850°F.
- (3) Leaded grades shall not be used where welded or in any application above 500°F.

**TABLE 2-1.4A STANDARD CLASS**

Temperature, °F	Working Pressures by Classes, psig							
	150	300	400	600	900	1500	2500	4500
-20 to 100	235	620	825	1,235	1,850	3,085	5,145	9,260
200	215	560	750	1,125	1,685	2,810	4,680	8,425
300	210	550	730	1,095	1,640	2,735	4,560	8,210
400	200	530	705	1,060	1,585	2,645	4,405	7,930
500	170	500	665	995	1,495	2,490	4,150	7,470
600	140	455	610	915	1,370	2,285	3,805	6,850
650	125	450	600	895	1,345	2,245	3,740	6,725
700	110	450	600	895	1,345	2,245	3,740	6,725
750	95	445	590	885	1,325	2,210	3,685	6,635
800	80	370	495	740	1,110	1,850	3,085	5,555
850	65	270	355	535	805	1,340	2,230	4,010
900	50	170	230	345	515	860	1,430	2,570
950	35	105	140	205	310	515	860	1,545
1000	20	50	70	105	155	260	430	770

(a)

**TABLE 2-1.4B SPECIAL CLASS**

Temperature, °F	Working Pressures by Classes, psig							
	150	300	400	600	900	1500	2500	4500
-20 to 100	245	645	860	1,285	1,930	3,215	5,360	9,645
200	245	645	860	1,285	1,930	3,215	5,360	9,645
300	245	645	860	1,285	1,930	3,215	5,360	9,645
400	245	645	860	1,285	1,930	3,215	5,360	9,645
500	245	645	860	1,285	1,930	3,215	5,360	9,645
600	230	595	795	1,190	1,785	2,975	4,955	8,920
650	225	585	780	1,170	1,750	2,920	4,865	8,760
700	220	580	770	1,160	1,735	2,895	4,820	8,680
750	210	555	740	1,105	1,660	2,765	4,610	8,295
800	180	465	620	925	1,390	2,315	3,860	6,945
850	130	335	445	670	1,005	1,670	2,785	5,015
900	85	215	285	430	645	1,070	1,785	3,215
950	50	130	170	260	385	645	1,070	1,930
1000	25	65	85	130	195	320	535	965

VALVES – FLANGED,  
THREADED, AND WELDING END

ASME B16.34a-1998

**TABLE 2-1.5**  
**RATINGS FOR GROUP 1.5 MATERIALS**

(a)

A 182 Gr. F1 (1)	A 204 Gr. A (1)	A 352 Gr. LC1 (3)	A 691 Gr. CM-70 (1)
A 204 Gr. A (1)	A 217 Gr. WC1 (1)(2)		

NOTES:

- (1) Upon prolonged exposure to temperatures above 875°F, the carbide phase of carbon-molybdenum steel may be converted to graphite. Permissible, but not recommended for prolonged use above 875°F.
- (2) Use normalized and tempered material only.
- (3) Not to be used over 650°F.

**TABLE 2-1.5A STANDARD CLASS**

Temperature, °F	Working Pressures by Classes, psig							
	150	300	400	600	900	1500	2500	4500
-20 to 100	265	695	925	1,390	2,085	3,470	5,785	10,415
200	260	680	905	1,360	2,035	3,395	5,660	10,185
300	230	655	870	1,305	1,955	3,260	5,435	9,780
400	200	640	855	1,280	1,920	3,200	5,330	9,595
500	170	620	830	1,245	1,865	3,105	5,180	9,320
600	140	605	805	1,210	1,815	3,025	5,040	9,070
650	125	590	785	1,175	1,765	2,940	4,905	8,825
700	110	570	755	1,135	1,705	2,840	4,730	8,515
750	95	530	710	1,065	1,595	2,660	4,430	7,970
800	80	510	675	1,015	1,525	2,540	4,230	7,610
850	65	485	650	975	1,460	2,435	4,060	7,305
900	50	450	600	900	1,350	2,245	3,745	6,740
950	35	280	375	560	845	1,405	2,345	4,215
1000	20	165	220	330	495	825	1,370	2,470

**TABLE 2-1.5B SPECIAL CLASS**

(a)

Temperature, °F	Working Pressures by Classes, psig							
	150	300	400	600	900	1500	2500	4500
-20 to 100	265	695	925	1,390	2,085	3,470	5,785	10,415
200	265	695	925	1,390	2,085	3,470	5,785	10,415
300	265	695	925	1,390	2,085	3,470	5,785	10,415
400	265	695	925	1,390	2,085	3,470	5,785	10,415
500	265	695	925	1,390	2,085	3,470	5,785	10,415
600	265	695	925	1,390	2,085	3,470	5,785	10,415
650	265	695	925	1,390	2,085	3,470	5,785	10,415
700	265	695	925	1,390	2,085	3,470	5,785	10,415
750	265	695	925	1,390	2,085	3,470	5,785	10,415
800	265	695	925	1,390	2,085	3,470	5,785	10,415
850	260	680	905	1,355	2,030	3,335	5,645	10,160
900	225	590	785	1,175	1,760	2,935	4,895	8,810
950	135	350	470	705	1,055	1,755	2,930	5,270
1000	80	205	275	410	615	1,030	1,715	3,085

(a)

**TABLE 2-1.6  
RATINGS FOR GROUP 1.6 MATERIALS**

A 335 Gr. P1 (1)(3)	A 387 Gr. 12 Cl. 1 (2)	A 387 Gr. 2 Cl. 2 (3)	A 691 Gr. ½CR (3)
A 369 Gr. FP1 (1)(3)	A 387 Gr. 2 Cl. 1 (3)		

NOTES:

- (1) Upon prolonged exposure to temperatures above 875°F, the carbide phase of carbon-molybdenum steel may be converted to graphite. Permissible, but not recommended for prolonged use above 875°F.
- (2) Permissible, but not recommended for prolonged use above 1100°F.
- (3) Not to be used over 1000°F.

**TABLE 2-1.6A STANDARD CLASS**

Temperature, °F	Working Pressures by Classes, psig							
	150	300	400	600	900	1500	2500	4500
-20 to 100	225	590	790	1,185	1,775	2,955	4,930	8,870
200	225	590	790	1,185	1,775	2,955	4,930	8,870
300	225	590	790	1,185	1,775	2,955	4,930	8,870
400	200	570	765	1,145	1,715	2,860	4,765	8,580
500	170	550	735	1,105	1,655	2,755	4,595	8,270
600	140	535	710	1,065	1,600	2,665	4,440	7,990
650	125	525	695	1,045	1,570	2,615	4,355	7,840
700	110	510	685	1,025	1,535	2,560	4,270	7,685
750	95	475	630	945	1,420	2,365	3,945	7,095
800	80	475	630	945	1,420	2,365	3,945	7,095
850	65	460	615	920	1,380	2,295	3,830	6,890
900	50	440	590	885	1,325	2,210	3,685	6,635
950	35	315	420	630	945	1,575	2,630	4,730
1000	20	200	270	405	605	1,010	1,685	3,035
1050	20(1)	155	205	310	465	770	1,285	2,315
1100	20(1)	95	130	190	290	480	800	1,440
1150	20(1)	60	80	125	185	310	515	925
1200	15(1)	40	50	75	115	190	315	565

NOTE:

- (1) For welding end valves only. Flanged end ratings terminate at 1000°F.

VALVES — FLANGED  
THREADED, AND WELDING END

ASME B16.34-1996

**TABLE 2-1.6 (CONT'D)  
RATINGS FOR GROUP 1.6 MATERIALS**

A 335 Gr. P1 (1)(3)	A 387 Gr. 12 Cl. 1 (2)	A 387 Gr. 2 Cl. 2 (3)	A 691 Gr. 1/2CR (3)
A 369 Gr. FP1 (1)(3)	A 387 Gr. 2 Cl. 1 (3)		

**NOTES:**

- (1) Upon prolonged exposure to temperatures above 875°F, the carbide phase of Carbon-molybdenum steel may be converted to graphite. Permissible, but not recommended for prolonged use above 875°F.
- (2) Permissible, but not recommended for prolonged use above 1100°F.
- (3) Not to be used over 1000°F.

**TABLE 2-1.6B SPECIAL CLASS**

Temperature, °F	Working Pressures by Classes, psig							
	150	300	400	600	900	1500	2500	4500
-20 to 100	225	590	790	1,185	1,775	2,955	4,930	8,870
200	225	590	790	1,185	1,775	2,955	4,930	8,870
300	225	590	790	1,185	1,775	2,955	4,930	8,870
400	225	590	790	1,185	1,775	2,955	4,930	8,870
500	225	590	790	1,185	1,775	2,955	4,930	8,870
600	225	590	790	1,185	1,775	2,955	4,930	8,870
650	225	590	790	1,185	1,775	2,955	4,930	8,870
700	225	590	790	1,185	1,775	2,955	4,930	8,870
750	225	590	790	1,185	1,775	2,955	4,930	8,870
800	225	590	790	1,185	1,775	2,955	4,930	8,870
850	220	575	765	1,150	1,725	2,870	4,785	8,615
900	210	555	735	1,105	1,660	2,765	4,605	8,295
950	150	395	525	790	1,185	1,970	3,285	5,915
1000	95	255	335	505	760	1,265	2,105	3,795
1050	75	195	255	385	580	965	1,605	2,895
1100	45	120	160	240	360	600	1,000	1,800
1150	30	75	105	155	230	385	645	1,155
1200	20	45	65	95	140	235	395	705

**TABLE 2-1.7  
RATINGS FOR GROUP 1.7 MATERIALS**

A 691 Gr. CM-75 A 182 Gr. F2 (3)	A 204 Gr. C (1)	A 217 Gr. WC4 (2)(3)	A 217 Gr. WC5 (2)
-------------------------------------	-----------------	----------------------	-------------------

**NOTES:**

- (1) Upon prolonged exposure to temperatures above 875°F, the carbide phase of Carbon-molybdenum steel may be converted to graphite. Permissible, but not recommended for prolonged use above 875°F.
- (2) Use normalized and tempered material only.
- (3) Not to be used over 1000°F.

**TABLE 2-1.7A STANDARD CLASS**

Temperature, °F	Working Pressures by Classes, psig							
	150	300	400	600	900	1500	2500	4500
-20 to 100	290	750	1,000	1,500	2,250	3,750	6,250	11,250
200	260	750	1,000	1,500	2,250	3,750	6,250	11,250
300	230	720	965	1,445	2,165	3,610	6,015	10,830
400	200	695	925	1,385	2,080	3,465	5,775	10,400
500	170	665	885	1,330	1,995	3,325	5,540	9,965
600	140	605	805	1,210	1,815	3,025	5,040	9,070
650	125	590	785	1,175	1,765	2,940	4,905	8,825
700	110	570	755	1,135	1,705	2,840	4,730	8,515
750	95	530	710	1,065	1,595	2,660	4,430	7,970
800	80	510	675	1,015	1,525	2,540	4,230	7,610
850	65	485	650	975	1,460	2,435	4,060	7,305
900	50	450	600	900	1,350	2,245	3,745	6,740
950	35	315	420	630	945	1,575	2,630	4,730
1000	20	200	270	405	605	1,010	1,685	3,035
1050	20(1)	160	210	315	475	790	1,315	2,365

**NOTE:**

- (1) For welding end valves only. Flanged end ratings terminate at 1000°F.

**TABLE 2-1.7B SPECIAL CLASS**

Temperature, °F	Working Pressures by Classes, psig							
	150	300	400	600	900	1500	2500	4500
-20 to 100	290	750	1,000	1,500	2,250	3,750	6,250	11,250
200	290	750	1,000	1,500	2,250	3,750	6,250	11,250
300	290	750	1,000	1,500	2,250	3,750	6,250	11,250
400	290	750	1,000	1,500	2,250	3,750	6,250	11,250
500	290	750	1,000	1,500	2,250	3,750	6,250	11,250
600	290	750	1,000	1,500	2,250	3,750	6,250	11,250
650	290	750	1,000	1,500	2,250	3,750	6,250	11,250
700	280	735	980	1,465	2,200	3,665	6,110	10,995
750	280	730	970	1,460	2,185	3,645	6,070	10,930
800	275	720	960	1,440	2,160	3,600	6,000	10,800
850	260	680	905	1,355	2,030	3,385	5,645	10,160
900	230	600	800	1,200	1,800	3,000	5,000	9,000
950	150	395	525	790	1,185	1,970	3,285	5,915
1000	95	255	335	505	760	1,265	2,105	3,795
1050	75	195	265	395	590	985	1,645	2,955

VALVES — FLANGED  
THREADED, AND WELDING END

ASME B16.34-1996

**TABLE 2-1.8  
RATINGS FOR GROUP 1.8 MATERIALS**

A 335 Gr. P11 (2)	A 369 Gr. FP11 (2)	A 387 Gr. 11 Cl. 1 (2)	A 691 Gr. 1CR (1)(2)
A 335 Gr. P12 (2)	A 369 Gr. FP12 (2)	A 387 Gr. 12 Cl. 2 (2)	A 691 Gr. 1½CR (2)
A 335 Gr. P22 (2)	A 369 Gr. FP22 (2)	A 387 Gr. 22 Cl. 1 (2)	A 691 Gr. 2¼CR (2)

**NOTES:**

- (1) Use normalized and tempered material only.
- (2) Permissible, but not recommended for prolonged use above 1100°F.

**TABLE 2-1.8A STANDARD CLASS**

Temperature, °F	Working Pressures by Classes, psig							
	150	300	400	600	900	1500	2500	4500
-20 to 100	235	620	825	1,235	1,860	3,085	5,145	9,260
200	220	570	765	1,145	1,715	2,860	4,765	8,580
300	215	555	745	1,115	1,670	2,785	4,645	8,360
400	200	555	740	1,105	1,660	2,765	4,610	8,300
500	170	555	740	1,105	1,660	2,765	4,610	8,300
600	140	555	740	1,105	1,660	2,765	4,610	8,300
650	125	555	740	1,105	1,660	2,765	4,610	8,300
700	110	545	725	1,085	1,630	2,715	4,525	8,145
750	95	515	685	1,030	1,545	2,570	4,285	7,715
800	80	510	675	1,015	1,525	2,540	4,230	7,610
850	65	485	650	975	1,460	2,435	4,060	7,305
900	50	450	600	900	1,350	2,245	3,745	6,740
950	35	320	425	640	955	1,595	2,655	4,785
1000	20	215	290	430	650	1,080	1,800	3,240
1050	20(1)	145	190	290	430	720	1,200	2,160
1100	20(1)	95	130	190	290	480	800	1,440
1150	20(1)	60	80	125	185	310	515	925
1200	15(1)	40	50	75	115	190	315	565

**NOTE:**

- (1) For welding end valves only. Flanged end ratings terminate at 1000°F.

**TABLE 2-1.8 (CONT'D)  
RATINGS FOR GROUP 1.8 MATERIALS**

A 335 Gr. P11 (2)	A 369 Gr. FP11 (2)	A 387 Gr. 11 Cl. 1 (2)	A 691 Gr. 1CR (1) (2)
A 335 Gr. P12 (2)	A 369 Gr. FP12 (2)	A 387 Gr. 12 Cl. 2 (2)	A 691 Gr. 1¼CR (2)
A 335 Gr. P22 (2)	A 369 Gr. FP22 (2)	A 387 Gr. 22 Cl. 1 (2)	A 691 Gr. 2¼CR (2)

**NOTES:**

- (1) Use normalized and tempered material only.
- (2) Permissible, but not recommended for prolonged use above 1100°F.

**TABLE 2-1.8B SPECIAL CLASS**

Temperature, °F	Working Pressures by Classes, psig							
	150	300	400	600	900	1500	2500	4500
-20 to 100	245	645	860	1,285	1,930	3,215	5,360	9,645
200	245	645	860	1,285	1,930	3,215	5,360	9,645
300	245	645	860	1,285	1,930	3,215	5,360	9,645
400	245	645	860	1,285	1,930	3,215	5,360	9,645
500	245	645	860	1,285	1,930	3,215	5,360	9,645
600	245	645	860	1,285	1,930	3,215	5,360	9,645
650	245	645	860	1,285	1,930	3,215	5,360	9,645
700	245	645	860	1,285	1,930	3,215	5,360	9,645
750	245	645	860	1,285	1,930	3,215	5,360	9,645
800	245	645	860	1,285	1,930	3,215	5,360	9,645
850	235	615	825	1,235	1,850	3,085	5,145	9,255
900	225	585	775	1,165	1,750	2,915	4,855	8,745
950	155	400	530	795	1,195	1,995	3,320	5,980
1000	105	270	360	540	810	1,350	2,250	4,050
1050	70	180	240	360	540	900	1,500	2,700
1100	45	120	160	240	360	600	1,000	1,800
1150	30	75	105	155	230	385	645	1,155
1200	20	45	65	95	140	235	395	705

VALVES — FLANGED  
 THREADED, AND WELDING END

ASME B16.34-1996

**TABLE 2-1.9  
 RATINGS FOR GROUP 1.9 MATERIALS**

A 182 Gr. F11 Cl. 2 (1)(2)    A 217 Gr. WC6 (1)(3)    A 387 Gr. 11, Cl. 2 (2)    A 739 Gr. B11 (2)  
 A 182 Gr. F12 Cl. 2 (1)(2)

**NOTES:**

- (1) Use normalized and tempered material only.
- (2) Permissible, but not recommended for prolonged use above 1100°F.
- (3) Not to be used over 1100°F.

**TABLE 2-1.9A    STANDARD CLASS**

Temperature, °F	Working Pressures by Classes, psig							
	150	300	400	600	900	1500	2500	4500
-20 to 100	290	750	1,000	1,500	2,250	3,750	6,250	11,250
200	260	750	1,000	1,500	2,250	3,750	6,250	11,250
300	230	720	965	1,445	2,165	3,610	6,015	10,830
400	200	695	925	1,385	2,080	3,465	5,775	10,400
500	170	665	885	1,330	1,995	3,325	5,540	9,965
600	140	605	805	1,210	1,815	3,025	5,040	9,070
650	125	590	785	1,175	1,765	2,940	4,905	8,825
700	110	570	755	1,135	1,705	2,840	4,730	8,515
750	95	530	710	1,065	1,595	2,660	4,430	7,970
800	80	510	675	1,015	1,525	2,540	4,230	7,610
850	65	485	650	975	1,460	2,435	4,060	7,305
900	50	450	600	900	1,350	2,245	3,745	6,740
950	35	320	425	640	955	1,595	2,655	4,785
1000	20	215	290	430	650	1,080	1,800	3,240
1050	20(1)	145	190	290	430	720	1,200	2,160
1100	20(1)	95	130	190	290	480	800	1,440
1150	20(1)	60	80	125	185	310	515	925
1200	15(1)	40	50	75	115	190	315	565

**NOTE:**

- (1) For welding end valves only. Flanged end ratings terminate at 1000°F.



**TABLE 2-1.9 (CONT'D)  
RATINGS FOR GROUP 1.9 MATERIALS**

A 182 Gr. F11 Cl. 2 (1)(2)	A 217 Gr. WC6 (1)(3)	A 387 Gr. 11, Cl. 2 (2)	A 739 Gr. B11 (2)
A 182 Gr. F12 Cl. 2 (1)(2)			

**NOTES:**

- (1) Use normalized and tempered material only.
- (2) Permissible, but not recommended for prolonged use above 1100°F.
- (3) Not to be used over 1100°F.

**TABLE 2-1.9B SPECIAL CLASS**

Temperature, °F	Working Pressures by Classes, psig							
	150	300	400	600	900	1500	2500	4500
-20 to 100	290	750	1,000	1,500	2,250	3,750	6,250	11,250
200	290	750	1,000	1,500	2,250	3,750	6,250	11,250
300	290	750	1,000	1,500	2,250	3,750	6,250	11,250
400	290	750	1,000	1,500	2,250	3,750	6,250	11,250
500	290	750	1,000	1,500	2,250	3,750	6,250	11,250
600	290	750	1,000	1,500	2,250	3,750	6,250	11,250
650	290	750	1,000	1,500	2,250	3,750	6,250	11,250
700	280	735	980	1,465	2,200	3,665	6,110	10,995
750	280	730	970	1,460	2,185	3,645	6,070	10,930
800	275	720	960	1,440	2,160	3,600	6,000	10,800
850	260	680	905	1,355	2,030	3,385	5,645	10,160
900	225	585	785	1,175	1,760	2,935	4,895	8,805
950	155	400	530	795	1,195	1,995	3,320	5,980
1000	105	270	360	540	810	1,350	2,250	4,050
1050	70	180	240	360	540	900	1,500	2,700
1100	45	120	160	240	360	600	1,000	1,800
1150	30	75	105	155	230	385	645	1,155
1200	20	45	65	95	140	235	395	705

VALVES — FLANGED  
THREADED, AND WELDING END

ASME B16.34-1996

**TABLE 2-1.10  
RATINGS FOR GROUP 1.10 MATERIALS**

A 182 Gr. F22 Cl. 3 (2)    A 217 Gr. WC9 (1)(3)    A 387 Gr. 22, Cl. 2 (2)    A 739 Gr. B22 (2)

**NOTES:**

- (1) Use normalized and tempered material only.
- (2) Permissible, but not recommended for prolonged use above 1100°F.
- (3) Not to be used over 1100°F.

**TABLE 2-1.10A STANDARD CLASS**

Temperature, °F	Working Pressures by Classes, psig							
	150	300	400	600	900	1500	2500	4500
-20 to 100	290	750	1,000	1,500	2,250	3,750	6,250	11,250
200	260	750	1,000	1,500	2,250	3,750	6,250	11,250
300	230	730	970	1,455	2,185	3,640	6,070	10,925
400	200	705	940	1,410	2,115	3,530	5,880	10,585
500	170	665	885	1,330	1,995	3,325	5,540	9,965
600	140	605	805	1,210	1,815	3,025	5,040	9,070
650	125	590	785	1,175	1,765	2,940	4,905	8,825
700	110	570	755	1,135	1,705	2,840	4,730	8,515
750	95	530	710	1,065	1,595	2,660	4,430	7,970
800	80	510	675	1,015	1,525	2,540	4,230	7,610
850	65	485	650	975	1,460	2,435	4,060	7,305
900	50	450	600	900	1,350	2,245	3,745	6,740
950	35	375	505	755	1,130	1,885	3,145	5,665
1000	20	260	345	520	780	1,305	2,170	3,910
1050	20(1)	175	235	350	525	875	1,455	2,625
1100	20(1)	110	145	220	330	550	915	1,645
1150	20(1)	70	90	135	205	345	570	1,030
1200	20(1)	40	55	80	125	205	345	615

**NOTE:**

- (1) For welding end valves only. Flanged end ratings terminate at 1000°F.

**TABLE 2-1.10 (CONT'D)  
RATINGS FOR GROUP 1.10 MATERIALS**

A 182 Gr. F22 Cl. 3 (2)    A 217 Gr. WC9 (1)(3)    A 387 Gr. 22, Cl. 2 (2)    A 739 Gr. B22 (2)

**NOTES:**

- (1) Use normalized and tempered material only.
- (2) Permissible, but not recommended for prolonged use above 1100°F.
- (3) Not to be used over 1100°F.

**TABLE 2-1.10B SPECIAL CLASS**

Temperature, °F	Working Pressures by Classes, psig							
	150	300	400	600	900	1500	2500	4500
-20 to 100	290	750	1,000	1,500	2,250	3,750	6,250	11,250
200	290	750	1,000	1,500	2,250	3,750	6,250	11,250
300	285	740	990	1,485	2,225	3,705	6,180	11,120
400	280	725	965	1,450	2,175	3,620	6,035	10,865
500	275	720	960	1,440	2,160	3,600	6,000	10,800
600	275	720	960	1,440	2,160	3,600	6,000	10,800
650	275	715	955	1,430	2,145	3,580	5,965	10,735
700	275	710	955	1,425	2,135	3,555	5,930	10,670
750	265	690	920	1,380	2,070	3,450	5,750	10,350
800	260	675	895	1,345	2,020	3,365	5,605	10,095
850	245	645	855	1,285	1,930	3,215	5,355	9,645
900	230	600	800	1,200	1,800	3,000	5,000	9,000
950	180	470	630	945	1,415	2,355	3,930	7,070
1000	125	325	435	650	975	1,630	2,715	4,885
1050	85	220	290	435	655	1,095	1,820	3,280
1100	55	135	185	275	410	685	1,145	2,055
1150	35	85	115	170	255	430	715	1,285
1200	25	50	70	105	155	255	430	770

VALVES — FLANGED  
 THREADED, AND WELDING END

ASME B16.34-1996

**TABLE 2-1.11  
 RATINGS FOR GROUP 1.11 MATERIALS**

A 182 Gr. F21 (2)	A 302 Gr. B (1)	A 302 Gr. D (1)	A 537 Cl. 2 (3)
A 302 Gr. A (1)	A 302 Gr. C (1)	A 387 Gr. 21, Cl. 2 (2)	

**NOTES:**

- (1) Upon prolonged exposure to temperatures above 875°F, the carbide phase of carbon-molybdenum steel may be converted to graphite. Permissible, but not recommended for prolonged use above 1000°F.
- (2) Permissible, but not recommended for prolonged use above 1100°F.
- (3) Not to be used over 700°F.

**TABLE 2-1.11A STANDARD CLASS**

Temperature, °F	Working Pressures by Classes, psig							
	150	300	400	600	900	1500	2500	4500
-20 to 100	290	750	1,000	1,500	2,250	3,750	6,250	11,250
200	260	750	1,000	1,500	2,250	3,750	6,250	11,250
300	230	730	970	1,455	2,185	3,640	6,070	10,925
400	200	705	940	1,410	2,115	3,530	5,880	10,585
500	170	665	885	1,330	1,995	3,325	5,540	9,965
600	140	605	805	1,210	1,815	3,025	5,040	9,070
650	125	590	785	1,175	1,765	2,940	4,905	8,825
700	110	570	755	1,135	1,705	2,840	4,730	8,515
750	95	530	710	1,065	1,595	2,660	4,430	7,970
800	80	510	675	1,015	1,525	2,540	4,230	7,610
850	65	485	650	975	1,460	2,435	4,060	7,305
900	50	450	600	900	1,345	2,245	3,745	6,735
950	35	280	375	560	845	1,405	2,345	4,215
1000	20	165	220	330	495	825	1,370	2,470
1050	20(1)	165	220	330	495	825	1,370	2,470
1100	20(1)	110	145	220	330	550	915	1,645
1150	20(1)	80	110	165	245	410	685	1,235
1200	20(1)	45	60	90	135	225	370	670

**NOTE:**

- (1) For welding end valves only. Flanged end ratings terminate at 1000°F.

**TABLE 2-1.11 (CONT'D)  
RATINGS FOR GROUP 1.11 MATERIALS**

A 182 Gr. F21 (2)	A 302 Gr. B (1)	A 302 Gr. D (1)	A 537 Cl. 2 (3)
A 302 Gr. A (1)	A 302 Gr. C (1)	A 387 Gr. 21, Cl. 2 (2)	

**NOTES:**

- (1) Upon prolonged exposure to temperatures above 875°F, the carbide phase of carbon-molybdenum steel may be converted to graphite. Permissible, but not recommended for prolonged use above 1000°F.
- (2) Permissible, but not recommended for prolonged use above 1100°F.
- (3) Not to be used over 700°F.

**TABLE 2-1.11B SPECIAL CLASS**

Temperature, °F	Working Pressures by Classes, psig							
	150	300	400	600	900	1500	2500	4500
-20 to 100	290	750	1,000	1,500	2,250	3,750	6,250	11,250
200	290	750	1,000	1,500	2,250	3,750	6,250	11,250
300	290	750	1,000	1,500	2,250	3,750	6,250	11,250
400	285	745	995	1,490	2,235	3,730	6,215	11,185
500	285	745	995	1,490	2,235	3,730	6,215	11,185
600	285	745	995	1,490	2,235	3,730	6,215	11,185
650	285	735	985	1,475	2,210	3,685	6,145	11,055
700	280	730	970	1,455	2,185	3,645	6,070	10,930
750	280	730	970	1,455	2,185	3,645	6,070	10,930
800	275	720	960	1,440	2,160	3,600	6,000	10,800
850	260	680	905	1,355	2,030	3,385	5,645	10,160
900	215	560	750	1,125	1,685	2,805	4,680	8,420
950	135	350	470	705	1,055	1,755	2,930	5,270
1000	80	205	275	410	615	1,030	1,715	3,085
1050	80	205	275	410	615	1,030	1,715	3,085
1100	55	135	185	275	410	685	1,145	2,055
1150	40	105	135	205	310	515	855	1,545
1200	20	55	75	110	165	280	465	835

VALVES — FLANGED  
THREADED, AND WELDING END

ASME B16.34-1996

**TABLE 2-1.12  
RATINGS FOR GROUP 1.12 MATERIALS**

A 335 Gr. P5	A 369 Gr. FP5	A 387 Gr. 5, Cl. 2	A 691 Gr. 5CR
A 335 Gr. P5b	A 387 Gr. Cl. 1		

**TABLE 2-1.12A STANDARD CLASS**

Temperature, °F	Working Pressures by Classes, psig							
	150	300	400	600	900	1500	2500	4500
-20 to 100	235	615	825	1,235	1,850	3,085	5,145	9,255
200	215	555	745	1,115	1,670	2,785	4,645	8,360
300	205	535	715	1,075	1,610	2,685	4,475	8,055
400	200	530	710	1,060	1,590	2,655	4,425	7,960
500	170	525	700	1,055	1,580	2,635	4,390	7,900
600	140	520	690	1,035	1,555	2,590	4,320	7,775
650	125	510	685	1,025	1,535	2,560	4,270	7,685
700	110	505	670	1,010	1,510	2,520	4,200	7,560
750	95	455	605	905	1,360	2,265	3,770	6,790
800	80	440	585	880	1,315	2,195	3,655	6,585
850	65	415	555	830	1,245	2,075	3,455	6,225
900	50	375	500	745	1,120	1,870	3,115	5,605
950	35	275	365	550	825	1,370	2,285	4,115
1000	20	200	265	400	595	995	1,655	2,985
1050	20(1)	145	190	290	430	720	1,200	2,160
1100	20(1)	100	135	200	300	495	830	1,490
1150	20(1)	60	80	125	185	310	515	925
1200	15(1)	35	45	70	105	170	285	515

NOTE:

(1) For welding end valves only. Flanged end ratings terminate at 1000°F.

**TABLE 2-1.12 (CONT'D)  
RATINGS FOR GROUP 1.12 MATERIALS**

A 335 Gr. P5	A 369 Gr. FP5	A 387 Gr. 5, Cl. 2	A 691 Gr. 5CR
A 335 Gr. P5b	A 387 Gr. Cl. 1		

**TABLE 2-1.12B SPECIAL CLASS**

Temperature, °F	Working Pressures by Classes, psig							
	150	300	400	600	900	1500	2500	4500
-20 to 100	245	645	855	1,285	1,930	3,215	5,355	9,645
200	245	645	855	1,285	1,930	3,215	5,355	9,645
300	240	620	830	1,245	1,865	3,105	5,180	9,320
400	235	615	825	1,235	1,850	3,085	5,145	9,255
500	235	615	825	1,235	1,850	3,085	5,145	9,255
600	235	610	810	1,215	1,825	3,045	5,070	9,130
650	230	595	795	1,190	1,785	2,980	4,965	8,935
700	225	585	785	1,175	1,760	2,935	4,895	8,805
750	215	565	755	1,130	1,695	2,830	4,715	8,485
800	210	550	730	1,095	1,645	2,745	4,570	8,230
850	200	520	690	1,035	1,555	2,595	4,320	7,780
900	180	465	625	935	1,400	2,335	3,895	7,005
950	130	345	455	685	1,030	1,715	2,855	5,145
1000	95	250	330	495	745	1,245	2,070	3,730
1050	70	180	240	360	540	900	1,500	2,700
1100	50	125	165	250	375	620	1,035	1,865
1150	30	75	105	155	230	385	645	1,155
1200	15	45	55	85	130	215	355	645

VALVES — FLANGED,  
THREADED, AND WELDING END

ASME B16.34a-1998

**TABLE 2-1.13  
RATINGS FOR GROUP 1.13 MATERIALS**

A 182 Gr. F5                      A 182 Gr. F5a                      A 217 Gr. C5 (1)

NOTE:

(1) Use normalized and tempered material only.

**TABLE 2-1.13A STANDARD CLASS**

Temperature, °F	Working Pressures by Classes, psig							
	150	300	400	600	900	1500	2500	4500
-20 to 100	290	750	1,000	1,500	2,250	3,750	6,250	11,250
200	260	745	995	1,490	2,235	3,725	6,205	11,170
300	230	715	955	1,430	2,150	3,580	5,965	10,740
400	200	705	940	1,410	2,115	3,530	5,880	10,585
500	170	665	885	1,330	1,995	3,325	5,540	9,965
600	140	605	805	1,210	1,815	3,025	5,040	9,070
650	125	590	785	1,175	1,765	2,940	4,905	8,825
700	110	570	755	1,135	1,705	2,840	4,730	8,515
750	95	530	705	1,055	1,585	2,640	4,400	7,920
800	80	510	675	1,015	1,525	2,540	4,230	7,610
850	65	485	645	965	1,450	2,415	4,030	7,250
900	50	370	495	740	1,110	1,850	3,085	5,555
950	35	275	365	550	825	1,370	2,285	4,115
1000	20	200	265	400	595	995	1,655	2,985
1050	20(1)	145	190	290	430	720	1,200	2,160
1100	20(1)	100	135	200	300	495	830	1,490
1150	20(1)	60	80	125	185	310	515	925
1200	15(1)	35	45	70	105	170	285	515

NOTE:

(1) For welding end valves only. Flanged end ratings terminate at 1000°F.

**TABLE 2-1.13B SPECIAL CLASS**

Temperature, °F	Working Pressures by Classes, psig							
	150	300	400	600	900	1500	2500	4500
-20 to 100	290	750	1,000	1,500	2,250	3,750	6,250	11,250
200	290	750	1,000	1,500	2,250	3,750	6,250	11,250
300	280	730	970	1,455	2,185	3,645	6,070	10,930
400	275	720	960	1,440	2,160	3,600	6,000	10,800
500	275	720	960	1,440	2,160	3,600	6,000	10,800
600	270	705	945	1,415	2,120	3,535	5,895	10,605
650	270	700	930	1,395	2,095	3,495	5,820	10,480
700	265	685	915	1,370	2,055	3,430	5,715	10,285
750	255	660	880	1,320	1,980	3,300	5,500	9,900
800	245	640	850	1,275	1,915	3,195	5,320	9,580
850	230	605	805	1,210	1,815	3,020	5,035	9,065
900	175	465	615	925	1,390	2,315	3,855	6,945
950	130	345	455	685	1,030	1,715	2,855	5,145
1000	95	250	330	495	745	1,245	2,070	3,730
1050	70	180	240	360	540	900	1,500	2,700
1100	50	125	165	250	375	620	1,035	1,865
1150	30	75	105	155	230	385	645	1,155
1200	15	45	55	85	130	215	355	645



**TABLE 2-1.14**  
**RATINGS FOR GROUP 1.14 MATERIALS**

A 182 Gr. F9

A 217 Gr. C12 (1)

NOTE:

(1) Use normalized and tempered material only.

**TABLE 2-1.14A STANDARD CLASS**

Temperature, °F	Working Pressures by Classes, psig							
	150	300	400	600	900	1500	2500	4500
-20 to 100	290	750	1,000	1,500	2,250	3,750	6,250	11,250
200	260	750	1,000	1,500	2,250	3,750	6,250	11,250
300	230	730	970	1,455	2,185	3,640	6,070	10,925
400	200	705	940	1,410	2,115	3,530	5,880	10,585
500	170	665	885	1,330	1,995	3,325	5,540	9,965
600	140	605	805	1,210	1,815	3,025	5,040	9,070
650	125	590	785	1,175	1,765	2,940	4,905	8,825
700	110	570	755	1,135	1,705	2,840	4,730	8,515
750	95	530	710	1,065	1,595	2,660	4,430	7,970
800	80	510	675	1,015	1,525	2,540	4,230	7,610
850	65	485	650	975	1,460	2,435	4,060	7,305
900	50	450	600	900	1,350	2,245	3,745	6,740
950	35	375	505	755	1,130	1,885	3,145	5,655
1000	20	255	340	505	760	1,270	2,115	3,805
1050	20(1)	170	230	345	515	855	1,430	2,570
1100	20(1)	115	150	225	340	565	945	1,695
1150	20(1)	75	100	150	225	375	630	1,130
1200	20(1)	50	70	105	155	255	430	770

NOTE:

(1) For welding end valves only. Flanged end ratings terminate at 1000°F.

(a)

**TABLE 2-1.14B SPECIAL CLASS**

Temperature, °F	Working Pressures by Classes, psig							
	150	300	400	600	900	1500	2500	4500
-20 to 100	290	750	1,000	1,500	2,250	3,750	6,250	11,250
200	290	750	1,000	1,500	2,250	3,750	6,250	11,250
300	290	750	1,000	1,500	2,250	3,750	6,250	11,250
400	290	750	1,000	1,500	2,250	3,750	6,250	11,250
500	290	750	1,000	1,500	2,250	3,750	6,250	11,250
600	290	750	1,000	1,500	2,250	3,750	6,250	11,250
650	290	750	1,000	1,500	2,250	3,750	6,250	11,250
700	280	735	980	1,465	2,200	3,665	6,110	10,995
750	280	730	970	1,460	2,185	3,645	6,070	10,930
800	275	720	960	1,440	2,160	3,600	6,000	10,800
850	260	680	905	1,355	2,030	3,385	5,645	10,160
900	230	600	800	1,200	1,800	3,000	5,000	9,000
950	180	470	630	945	1,415	2,355	3,930	7,070
1000	120	315	425	635	950	1,585	2,645	4,755
1050	80	215	285	430	645	1,070	1,785	3,215
1100	55	140	190	285	425	710	1,180	2,120
1150	35	95	125	190	285	470	785	1,415
1200	25	65	85	130	195	320	535	965

VALVES — FLANGED,  
THREADED, AND WELDING END

ASME B16.34a-1998

**TABLE 2-1.15**  
**RATINGS FOR GROUP 1.15 MATERIALS**

(a)

A 182 Gr. F91	A 217 Gr. C12A	A 335 Gr. P91	A 387 Gr. 91 Cl.2
---------------	----------------	---------------	-------------------

**TABLE 2-1.15A STANDARD CLASS**

(a)

Temperature, °F	Working Pressure by Classes, psig							
	150	300	400	600	900	1500	2500	4500
-20 to 100	290	750	1,000	1,500	2,250	3,750	6,250	11,250
200	260	750	1,000	1,500	2,250	3,750	6,250	11,250
300	230	730	970	1,455	2,185	3,640	6,070	10,925
400	200	705	940	1,410	2,115	3,530	5,880	10,585
500	170	665	885	1,330	1,995	3,325	5,540	9,965
600	140	605	805	1,210	1,815	3,025	5,040	9,070
650	125	590	785	1,175	1,765	2,940	4,905	8,825
700	110	570	755	1,135	1,705	2,840	4,730	8,515
750	95	530	710	1,065	1,595	2,660	4,430	7,970
800	80	510	675	1,015	1,525	2,540	4,230	7,610
850	65	485	650	975	1,460	2,435	4,060	7,305
900	50	450	600	900	1,350	2,245	3,745	6,740
950	35	385	515	775	1,160	1,930	3,220	5,795
1000	20	365	485	725	1,090	1,820	3,030	5,450
1050	20(1)	360	480	720	1,080	1,800	3,000	5,400
1100	20(1)	300	400	605	905	1,510	2,515	4,525
1150	20(1)	225	295	445	670	1,115	1,855	3,345
1200	20(1)	145	190	290	430	720	1,200	2,160

NOTE:

(1) For welding end only. Flanged end ratings terminate at 1000°F.

**TABLE 2-1.15B SPECIAL CLASS**

(a)

Temperature, °F	Working Pressure by Classes, psig							
	150	300	400	600	900	1500	2500	4500
-20 to 100	290	750	1,000	1,500	2,250	3,750	6,250	11,250
200	290	750	1,000	1,500	2,250	3,750	6,250	11,250
300	290	750	1,000	1,500	2,250	3,750	6,250	11,250
400	290	750	1,000	1,500	2,250	3,750	6,250	11,250
500	290	750	1,000	1,500	2,250	3,750	6,250	11,250
600	290	750	1,000	1,500	2,250	3,750	6,250	11,250
650	290	750	1,000	1,500	2,250	3,750	6,250	11,250
700	280	735	980	1,465	2,200	3,665	6,110	10,995
750	280	730	970	1,460	2,185	3,645	6,070	10,930
800	275	720	960	1,440	2,160	3,600	6,000	10,800
850	260	680	905	1,355	2,030	3,385	5,645	10,160
900	230	600	800	1,200	1,800	3,000	5,000	9,000
950	180	470	630	945	1,415	2,360	3,930	7,070
1000	160	420	560	840	1,260	2,105	3,505	6,310
1050	160	420	560	840	1,260	2,105	3,505	6,310
1100	145	375	505	755	1,130	1,885	3,145	5,655
1150	105	280	370	555	835	1,395	2,320	4,180
1200	70	180	240	360	540	900	1,500	2,700

VALVES — FLANGED,  
THREADED, AND WELDING END

ASME B16.34a-1998

**TABLE 2-2.1  
RATINGS FOR GROUP 2.1 MATERIALS**

A 182 Gr. F304 (1)	A 312 Gr. TP304 (1)	A 358 Gr. 304 (1)	A 430 Gr. FP304H
A 182 Gr. F304H	A 312 Gr. TP304H	A 376 Gr. TP304 (1)	A 479 Gr. 304 (1)
A 240 Gr. 304 (1)	A 351 Gr. CF3 (2)	A 376 Gr. TP304H	A 479 Gr. 304H
A 240 Gr. 304H	A 351 Gr. CF8 (1)	A 430 Gr. FP304 (1)	

**NOTES:**

- (1) At temperatures over 1000°F, use only when the carbon content is 0.04% or higher.
- (2) Not to be used over 800°F.

**TABLE 2-2.1A STANDARD CLASS**

(a)

Temperature, °F	Working Pressures by Classes, psig							
	150	300	400	600	900	1500	2500	4500
-20 to 100	275	720	960	1,440	2,160	3,600	6,000	10,800
200	230	600	800	1,200	1,800	3,000	5,000	9,000
300	205	540	720	1,080	1,620	2,700	4,500	8,100
400	190	495	660	995	1,490	2,485	4,140	7,450
500	170	465	620	930	1,395	2,330	3,880	6,985
600	140	435	580	875	1,310	2,185	3,640	6,550
650	125	430	575	860	1,290	2,150	3,580	6,445
700	110	425	565	850	1,275	2,125	3,540	6,370
750	95	415	555	830	1,245	2,075	3,460	6,230
800	80	405	540	805	1,210	2,015	3,360	6,050
850	65	395	530	790	1,190	1,980	3,300	5,940
900	50	390	520	780	1,165	1,945	3,240	5,830
950	35	380	510	765	1,145	1,910	3,180	5,725
1000	20	320	430	640	965	1,605	2,675	4,815
1050	20(1)	310	410	615	925	1,545	2,570	4,630
1100	20(1)	255	345	515	770	1,285	2,145	3,855
1150	20(1)	200	265	400	595	995	1,655	2,985
1200	20(1)	155	205	310	465	770	1,285	2,315
1250	20(1)	115	150	225	340	565	945	1,695
1300	20(1)	85	115	170	255	430	715	1,285
1350	20(1)	60	80	125	185	310	515	925
1400	20(1)	50	65	95	145	240	400	720
1450	15(1)	35	45	70	105	170	285	515
1500	10(1)	25	35	55	80	135	230	410

**NOTE:**

- (1) For welding end valves only. Flanged end ratings terminate at 1000°F.

**TABLE 2-2.1 (CONT'D)  
RATINGS FOR GROUP 2.1 MATERIALS**

A 182 Gr. F304 (1)	A 312 Gr. TP304 (1)	A 358 Gr. 304 (1)	A 430 Gr. FP304H
A 182 Gr. F304H	A 312 Gr. TP304H	A 376 Gr. TP304 (1)	A 479 Gr. 304 (1)
A 240 Gr. 304 (1)	A 351 Gr. CF3 (2)	A 376 Gr. TP304H	A 479 Gr. 304H
A 240 Gr. 304H	A 351 Gr. CF8 (1)	A 430 Gr. FP304 (1)	

**NOTES:**

- (1) At temperatures over 1000°F, use only when the carbon content is 0.04% or higher.
- (2) Not to be used over 800°F.

(a) **TABLE 2-2.1B SPECIAL CLASS**

Temperature, °F	Working Pressures by Classes, psig							
	150	300	400	600	900	1500	2500	4500
-20 to 100	290	750	1,000	1,500	2,250	3,750	6,250	11,250
200	255	670	890	1,335	2,005	3,345	5,570	10,030
300	230	600	800	1,200	1,800	3,000	5,000	9,000
400	210	555	735	1,105	1,660	2,765	4,605	8,295
500	200	520	690	1,035	1,555	2,595	4,320	7,780
600	185	490	650	975	1,465	2,440	4,065	7,315
650	185	480	640	960	1,440	2,395	3,995	7,190
700	180	470	630	945	1,415	2,355	3,930	7,070
750	175	465	615	925	1,390	2,315	3,855	6,945
800	175	450	600	900	1,350	2,250	3,750	6,750
850	170	440	590	885	1,325	2,205	3,680	6,620
900	165	435	575	865	1,300	2,165	3,605	6,495
950	165	425	565	850	1,275	2,120	3,535	6,365
1000	155	405	545	815	1,220	2,035	3,395	6,105
1050	150	385	515	770	1,155	1,930	3,215	5,785
1100	125	320	430	645	965	1,605	2,680	4,820
1150	95	250	330	495	745	1,245	2,070	3,730
1200	75	195	255	385	580	965	1,605	2,895
1250	55	140	190	285	425	705	1,180	2,120
1300	40	105	145	215	320	535	895	1,605
1350	30	75	105	155	230	385	645	1,155
1400	25	60	80	120	180	300	500	900
1450	15	45	55	85	130	215	355	645
1500	15	35	45	70	105	170	285	515

VALVES — FLANGED,  
THREADED, AND WELDING END

ASME B16.34a-1998

**TABLE 2-2.2**  
**RATINGS FOR GROUP 2.2 MATERIALS**

(a)

A 182 Gr. F316 (1)	A 312 Gr. TP316 (1)	A 351 Gr. CF8A (2)	A 430 Gr. FP316 (1)
A 182 Gr. F316H	A 312 Gr. TP316H	A 351 Gr. CF8M (1)	A 430 Gr. FP316H
A 240 Gr. 316 (1)	A 312 Gr. TP317 (1)	A 358 Gr. 316 (1)	A 479 Gr. 316 (1)
A 240 Gr. 316H	A 351 Gr. CF3A (2)	A 376 Gr. TP316 (1)	A 479 Gr. 316H
A 240 Gr. 317 (1)	A 351 Gr. CF3M (3)	A 376 Gr. TP316H	A 351 Gr. CG8M (4)

**NOTES:**

- (1) At temperatures over 1000°F, use only when the carbon content is 0.04% or higher.
- (2) Not to be used over 650°F.
- (3) Not to be used over 850°F.
- (4) Not to be used over 1000°F.

**TABLE 2-2.2A STANDARD CLASS**

Temperature, °F	Working Pressures by Classes, psig							
	150	300	400	600	900	1500	2500	4500
-20 to 100	275	720	960	1,440	2,160	3,600	6,000	10,800
200	235	620	825	1,240	1,860	3,095	5,160	9,290
300	215	560	745	1,120	1,680	2,795	4,660	8,390
400	195	515	685	1,025	1,540	2,570	4,280	7,705
500	170	480	635	955	1,435	2,390	3,980	7,165
600	140	450	600	900	1,355	2,255	3,760	6,770
650	125	445	590	890	1,330	2,220	3,700	6,660
700	110	430	580	870	1,305	2,170	3,620	6,515
750	95	425	570	855	1,280	2,135	3,560	6,410
800	80	420	565	845	1,265	2,110	3,520	6,335
850	65	420	555	835	1,255	2,090	3,480	6,265
900	50	415	555	830	1,245	2,075	3,460	6,230
950	35	385	515	775	1,160	1,930	3,220	5,795
1000	20	350	465	700	1,050	1,750	2,915	5,245
1050	20(1)	345	460	685	1,030	1,720	2,865	5,155
1100	20(1)	305	405	610	915	1,525	2,545	4,575
1150	20(1)	235	315	475	710	1,185	1,970	3,550
1200	20(1)	185	245	370	555	925	1,545	2,775
1250	20(1)	145	195	295	440	735	1,230	2,210
1300	20(1)	115	155	235	350	585	970	1,750
1350	20(1)	95	130	190	290	480	800	1,440
1400	20(1)	75	100	150	225	380	630	1,130
1450	20(1)	60	80	115	175	290	485	875
1500	20(1)	40	55	85	125	205	345	620

**NOTE:**

- (1) For welding end valves only. Flanged end ratings terminate at 1000°F.

(a)

**TABLE 2-2.2 (CONT'D)  
RATINGS FOR GROUP 2.2 MATERIALS**

A 182 Gr. F316 (1)	A 312 Gr. TP316 (1)	A 351 Gr. CF8A (2)	A 430 Gr. FP316 (1)
A 182 Gr. F316H	A 312 Gr. TP316H	A 351 Gr. CF8M (1)	A 430 Gr. FP316H
A 240 Gr. 316 (1)	A 312 Gr. TP317 (1)	A 358 Gr. 316 (1)	A 479 Gr. 316 (1)
A 240 Gr. 316H	A 351 Gr. CF3A (2)	A 376 Gr. TP316 (1)	A 479 Gr. 316H
A 240 Gr. 317 (1)	A 351 Gr. CF3M (3)	A 376 Gr. TP316H	A 351 Gr. CG8M (4)

NOTES:

- (1) At temperatures over 1000°F, use only when the carbon content is 0.04% or higher.
- (2) Not to be used over 650°F.
- (3) Not to be used over 850°F.
- (4) Not to be used over 1000°F.

(a)

**TABLE 2-2.2B SPECIAL CLASS**

Temperature, °F	Working Pressures by Classes, psig							
	150	300	400	600	900	1500	2500	4500
-20 to 100	290	750	1,000	1,500	2,250	3,750	6,250	11,250
200	265	690	920	1,380	2,070	3,450	5,750	10,350
300	240	625	830	1,250	1,870	3,120	5,200	9,360
400	220	570	760	1,140	1,710	2,850	4,750	8,550
500	205	530	710	1,065	1,595	2,655	4,430	7,970
600	195	505	670	1,005	1,510	2,520	4,195	7,555
650	190	495	655	985	1,480	2,465	4,105	7,395
700	185	485	645	970	1,455	2,420	4,035	7,265
750	180	475	635	950	1,425	2,380	3,965	7,135
800	180	470	630	945	1,415	2,355	3,930	7,070
850	180	465	620	930	1,400	2,330	3,885	6,990
900	175	465	615	925	1,390	2,315	3,855	6,945
950	175	460	610	915	1,375	2,290	3,815	6,870
1000	160	420	560	840	1,260	2,105	3,505	6,310
1050	160	420	560	840	1,260	2,105	3,505	6,310
1100	145	380	510	765	1,145	1,905	3,180	5,720
1150	115	295	395	590	885	1,480	2,465	4,435
1200	90	230	310	465	695	1,155	1,930	3,470
1250	70	185	245	370	555	920	1,535	2,765
1300	55	145	195	290	435	730	1,215	2,185
1350	45	120	160	240	360	600	1,000	1,800
1400	35	95	125	190	285	470	785	1,415
1450	30	75	100	145	220	365	610	1,095
1500	20	50	70	105	155	260	430	770

VALVES — FLANGED,  
THREADED, AND WELDING END

ASME B16.34a-1998

**TABLE 2-2.3  
RATINGS FOR GROUP 2.3 MATERIALS**

A 182 Gr. F304L (1)	A 240 Gr. 304L (1)	A 312 Gr. TP304L (1)	A 479 Gr. 304L (1)
A 182 Gr. F316L	A 240 Gr. 316L	A 312 Gr. TP316L	A 479 Gr. 316L

NOTE:

(1) Not to be used over 800°F.

**TABLE 2-2.3A STANDARD CLASS**

Temperature, °F	Working Pressures by Classes, psig							
	150	300	400	600	900	1500	2500	4500
-20 to 100	230	600	800	1,200	1,800	3,000	5,000	9,000
200	195	505	675	1,015	1,520	2,530	4,220	7,595
300	175	455	605	910	1,360	2,270	3,780	6,805
400	160	415	550	825	1,240	2,065	3,440	6,190
500	145	380	510	765	1,145	1,910	3,180	5,725
600	140	360	480	720	1,080	1,800	3,000	5,400
650	125	350	470	700	1,050	1,750	2,920	5,255
700	110	345	460	685	1,030	1,715	2,860	5,150
750	95	335	450	670	1,010	1,680	2,800	5,040
800	80	330	440	660	985	1,645	2,740	4,930
850	65	320	430	645	965	1,610	2,680	4,825

**TABLE 2-2.3B SPECIAL CLASS**

(a)

Temperature, °F	Working Pressures by Classes, psig							
	150	300	400	600	900	1500	2500	4500
-20 to 100	255	670	890	1,340	2,005	3,345	5,570	10,030
200	215	565	755	1,130	1,695	2,825	4,710	8,480
300	195	505	675	1,010	1,520	2,530	4,215	7,585
400	175	460	615	920	1,385	2,305	3,840	6,910
500	165	425	570	850	1,280	2,130	3,550	6,390
600	155	400	535	805	1,205	2,010	3,350	6,025
650	150	390	520	780	1,170	1,950	3,250	5,850
700	145	380	510	765	1,145	1,910	3,180	5,720
750	145	375	500	745	1,120	1,865	3,110	5,595
800	140	365	490	735	1,100	1,835	3,060	5,505
850	140	360	480	720	1,075	1,795	2,990	5,385

**TABLE 2-2.4  
RATINGS FOR GROUP 2.4 MATERIALS**

A 182 Gr. F321 (2)	A 312 Gr. TP321 (2)	A 376 Gr. TP321 (2)	A 430 Gr. FP321H
A 182 Gr. F321H (1)	A 312 Gr. TP321H	A 376 Gr. TP321H	A 479 Gr. 321 (2)
A 240 Gr. 321 (2)	A 358 Gr. 321 (2)	A 430 Gr. FP321 (2)	A 479 Gr. 321H
A 240 Gr. 321H (1)			

**NOTES:**

- (1) At temperatures over 1000°F, use only if the material is heat treated by heating to a minimum temperature of 2000°F.
- (2) Not to be used over 1000°F.

(a) **TABLE 2-2.4A STANDARD CLASS**

Temperature, °F	Working Pressures by Classes, psig							
	150	300	400	600	900	1500	2500	4500
-20 to 100	275	720	960	1,440	2,160	3,600	6,000	10,800
200	245	645	860	1,290	1,935	3,230	5,380	9,685
300	230	595	795	1,190	1,785	2,975	4,960	8,930
400	200	550	735	1,105	1,655	2,760	4,600	8,280
500	170	515	685	1,030	1,545	2,570	4,285	7,715
600	140	485	650	975	1,460	2,435	4,060	7,310
650	125	480	635	955	1,435	2,390	3,980	7,165
700	110	465	620	930	1,395	2,330	3,880	6,985
750	95	460	610	915	1,375	2,290	3,820	6,875
800	80	450	600	900	1,355	2,255	3,760	6,770
850	65	445	595	895	1,340	2,230	3,720	6,695
900	50	440	590	885	1,325	2,210	3,680	6,625
950	35	385	515	775	1,160	1,930	3,220	5,795
1000	20	355	475	715	1,070	1,785	2,970	5,350
1050	20(1)	315	415	625	940	1,565	2,605	4,690
1100	20(1)	270	360	545	815	1,360	2,265	4,075
1150	20(1)	235	315	475	710	1,185	1,970	3,550
1200	20(1)	185	245	370	555	925	1,545	2,775
1250	20(1)	140	185	280	420	705	1,170	2,110
1300	20(1)	110	145	220	330	550	915	1,645
1350	20(1)	85	115	170	255	430	715	1,285
1400	20(1)	65	85	130	195	325	545	975
1450	20(1)	50	70	105	155	255	430	770
1500	20(1)	40	50	75	115	190	315	565

**NOTE:**

- (1) For welding end valves only. Flanged end ratings terminate at 1000°F.



VALVES — FLANGED  
 THREADED, AND WELDING END

ASME B16.34-1996

**TABLE 2-2.4 (CONT'D)  
 RATINGS FOR GROUP 2.4 MATERIALS**

A 182 Gr. F321 (2)	A 312 Gr. TP321 (2)	A 376 Gr. TP321 (2)	A 430 Gr. FP321H
A 182 Gr. F321H (1)	A 312 Gr. TP321H	A 376 Gr. TP321H	A 479 Gr. 321 (2)
A 240 Gr. 321 (2)	A 358 Gr. 321 (2)	A 430 Gr. FP321 (2)	A 479 Gr. 321H
A 240 Gr. 321H (1)			

**NOTES:**

- (1) At temperatures over 1000°F, use only if the material is heat treated by heating to a minimum temperature of 2000°F.
- (2) Not to be used over 1000°F.

**TABLE 2-2.4B SPECIAL CLASS**

Temperature, °F	Working Pressures by Classes, psig							
	150	300	400	600	900	1500	2500	4500
-20 to 100	290	750	1,000	1,500	2,250	3,750	6,250	11,250
200	260	680	910	1,365	2,045	3,405	5,680	10,220
300	235	610	810	1,215	1,825	3,045	5,070	9,130
400	210	555	735	1,105	1,660	2,765	4,605	8,295
500	195	515	685	1,030	1,545	2,570	4,285	7,715
600	185	490	650	975	1,465	2,445	4,070	7,330
650	185	480	640	960	1,440	2,400	4,000	7,200
700	180	470	630	945	1,415	2,355	3,930	7,070
750	180	465	625	935	1,400	2,335	3,895	7,005
800	175	465	615	925	1,390	2,315	3,855	6,945
850	175	460	610	915	1,375	2,295	3,820	6,880
900	175	455	605	910	1,365	2,270	3,785	6,815
950	175	455	605	910	1,365	2,270	3,785	6,815
1000	160	420	560	840	1,260	2,105	3,505	6,310
1050	155	405	545	815	1,220	2,035	3,395	6,105
1100	135	355	470	705	1,060	1,770	2,945	5,305
1150	115	295	395	590	885	1,480	2,465	4,435
1200	90	230	310	465	695	1,155	1,930	3,470
1250	65	175	235	350	525	880	1,465	2,635
1300	55	135	185	275	410	685	1,145	2,055
1350	40	105	145	215	320	535	895	1,605
1400	30	80	110	165	245	405	680	1,220
1450	25	65	85	130	195	320	535	965
1500	20	45	65	95	140	235	395	705

**TABLE 2-2.5  
RATINGS FOR GROUP 2.5 MATERIALS**

A 182 Gr. F347 (2)	A 240 Gr. 348 (2)	A 351 Gr. CF8C (3)	A 430 Gr. FP347 (2)
A 182 Gr. F347H (1)	A 240 Gr. 348H (1)	A 358 Gr. 347 (2)	A 430 Gr. FP347H
A 182 Gr. F348 (2)	A 312 Gr. TP347 (2)	A 376 Gr. TP347 (2)	A 479 Gr. 347 (2)
A 182 Gr. F348H (1)	A 312 Gr. TP347H	A 376 Gr. TP347H	A 479 Gr. 347H
A 240 Gr. 347 (2)	A 312 Gr. TP348 (2)	A 376 Gr. TP348 (2)	A 479 Gr. 348 (2)
A 240 Gr. 347H (1)	A 312 Gr. TP348H		A 479 Gr. 348H

**NOTES:**

- (1) For temperatures over 1000°F, use only if the material is heat treated by heating to a minimum temperature of 2000°F.
- (2) Not to be used over 1000°F.
- (3) At temperatures over 1000°F, use the material only when the carbon content is 0.04% or higher.

**TABLE 2-2.5A STANDARD CLASS**

Temperature, °F	Working Pressures by Classes, psig							
	150	300	400	600	900	1500	2500	4500
-20 to 100	275	720	960	1,440	2,160	3,600	6,000	10,800
200	255	660	880	1,320	1,980	3,300	5,500	9,900
300	230	615	820	1,230	1,845	3,070	5,120	9,215
400	200	575	765	1,145	1,720	2,870	4,780	8,605
500	170	540	720	1,080	1,620	2,700	4,500	8,100
600	140	515	685	1,025	1,540	2,570	4,280	7,705
650	125	505	670	1,010	1,510	2,520	4,200	7,560
700	110	495	660	990	1,485	2,470	4,120	7,415
750	95	490	655	985	1,475	2,460	4,100	7,380
800	80	485	650	975	1,460	2,435	4,060	7,310
850	65	485	645	970	1,455	2,425	4,040	7,270
900	50	450	600	900	1,350	2,245	3,745	6,740
950	35	385	515	775	1,160	1,930	3,220	5,795
1000	20	365	485	725	1,090	1,820	3,030	5,450
1050	20(1)	360	480	720	1,080	1,800	3,000	5,400
1100	20(1)	325	430	645	965	1,610	2,685	4,835
1150	20(1)	275	365	550	825	1,370	2,285	4,115
1200	20(1)	170	230	345	515	855	1,430	2,570
1250	20(1)	125	165	245	370	615	1,030	1,850
1300	20(1)	95	125	185	280	465	770	1,390
1350	20(1)	70	90	135	205	345	570	1,030
1400	20(1)	55	75	110	165	275	455	825
1450	15(1)	40	55	80	125	205	345	615
1500	15(1)	35	45	70	105	170	285	515

**NOTE:**

- (1) For welding end valves only. Flanged end ratings terminate at 1000°F.

VALVES — FLANGED  
 THREADED, AND WELDING END

ASME B16.34-1996

**TABLE 2-2.5 (CONT'D)  
 RATINGS FOR GROUP 2.5 MATERIALS**

A 182 Gr. F347 (2)	A 240 Gr. 348 (2)	A 351 Gr. CF8C (3)	A 430 Gr. FP347 (2)
A 182 Gr. F347H (1)	A 240 Gr. 348H (1)	A 358 Gr. 347 (2)	A 430 Gr. FP347H
A 182 Gr. F348 (2)	A 312 Gr. TP347 (2)	A 376 Gr. TP347 (2)	A 479 Gr. 347 (2)
A 182 Gr. F348H (1)	A 312 Gr. TP347H	A 376 Gr. TP347H	A 479 Gr. 347H
A 240 Gr. 347 (2)	A 312 Gr. TP348 (2)	A 376 Gr. TP348 (2)	A 479 Gr. 348 (2)
A 240 Gr. 347H (1)	A 312 Gr. TP348H		A 479 Gr. 348H

**NOTES:**

- (1) For temperatures over 1000°F, use only if the material is heat treated by heating to a minimum temperature of 2000°F.
- (2) Not to be used over 1000°F.
- (3) At temperatures over 1000°F, use the material only when the carbon content is 0.04% or higher.

**TABLE 2-2.5B SPECIAL CLASS**

Temperature, °F	Working Pressures by Classes, psig							
	150	300	400	600	900	1500	2500	4500
-20 to 100	290	750	1,000	1,500	2,250	3,750	6,250	11,250
200	275	715	955	1,430	2,145	3,580	5,965	10,735
300	250	655	875	1,310	1,965	3,280	5,465	9,835
400	235	615	825	1,235	1,850	3,085	5,145	9,255
500	230	595	795	1,190	1,785	2,980	4,965	8,935
600	220	575	765	1,145	1,720	2,865	4,775	8,600
650	215	565	750	1,125	1,690	2,815	4,690	8,440
700	210	550	735	1,105	1,655	2,760	4,600	8,275
750	210	550	730	1,095	1,645	2,745	4,570	8,230
800	210	545	725	1,090	1,630	2,720	4,530	8,155
850	205	540	720	1,080	1,625	2,705	4,510	8,115
900	205	540	720	1,075	1,615	2,690	4,485	8,075
950	180	470	630	945	1,415	2,360	3,930	7,070
1000	160	420	560	840	1,260	2,105	3,505	6,310
1050	160	420	560	840	1,260	2,105	3,505	6,310
1100	155	405	540	805	1,210	2,015	3,360	6,045
1150	130	345	455	685	1,030	1,715	2,855	5,145
1200	80	215	285	430	645	1,070	1,785	3,215
1250	60	155	205	310	465	770	1,285	2,315
1300	45	115	155	230	345	580	965	1,735
1350	35	85	115	170	255	430	715	1,285
1400	25	70	90	135	205	345	570	1,030
1450	20	50	70	105	155	255	430	770
1500	15	45	55	85	130	215	355	645

**TABLE 2-2.6  
RATINGS FOR GROUP 2.6 MATERIALS**

A 240 Gr. 309S (1)(2)(3)	A 351 Gr. CH8 (1)	A 351 Gr. CH20 (1)	A 358 Gr. 309H
A 312 Gr. TP309H	A 240 Gr. 309H		

**NOTES:**

- (1) At temperatures over 1000°F, use only when the carbon content is 0.04% or higher.
- (2) For temperatures above 1000°F, use only if the material is solution heat treated to the minimum temperature specified in the material specification but not lower than 1900°F and quenching in water or rapidly cooling by other means.
- (3) This material should be used for service temperatures 1050°F and above only when assurance is provided that grain size is not finer than ASTM 6.

**TABLE 2-2.6A STANDARD CLASS**

Temperature, °F	Working Pressures by Classes, psig							
	150	300	400	600	900	1500	2500	4500
-20 to 100	260	670	895	1,345	2,015	3,360	5,600	10,080
200	230	605	805	1,210	1,815	3,025	5,040	9,070
300	220	570	760	1,140	1,705	2,845	4,740	8,530
400	200	535	710	1,065	1,600	2,665	4,440	7,990
500	170	505	670	1,010	1,510	2,520	4,200	7,560
600	140	480	635	955	1,435	2,390	3,980	7,165
650	125	465	620	930	1,395	2,330	3,880	6,985
700	110	455	610	910	1,370	2,280	3,800	6,840
750	95	445	595	895	1,340	2,230	3,720	6,695
800	80	435	580	870	1,305	2,170	3,620	6,515
850	65	425	565	850	1,275	2,125	3,540	6,370
900	50	415	555	830	1,245	2,075	3,460	6,230
950	35	385	515	775	1,160	1,930	3,220	5,795
1000	20	335	450	670	1,010	1,680	2,800	5,040
1050	20(1)	290	390	585	875	1,460	2,430	4,370
1100	20(1)	225	300	445	670	1,115	1,860	3,345
1150	20(1)	170	230	345	515	860	1,430	2,570
1200	20(1)	130	175	260	390	650	1,085	1,955
1250	20(1)	100	135	200	300	495	830	1,490
1300	20(1)	80	105	160	235	395	660	1,185
1350	20(1)	60	80	115	175	290	485	875
1400	20(1)	45	60	90	135	225	370	670
1450	10(1)	30	40	60	95	155	260	465
1500	10(1)	25	30	50	70	120	200	360

**NOTE:**

- (1) For welding end valves only. Flanged end ratings terminate at 1000°F.

VALVES — FLANGED  
 THREADED, AND WELDING END

ASME B16.34-1996

**TABLE 2-2.6 (CONT'D)  
 RATINGS FOR GROUP 2.6 MATERIALS**

A 240 Gr. 309S (1)(2)(3)	A 351 Gr. CH8 (1)	A 351 Gr. CH20 (1)	A 358 Gr. 309H
A 312 Gr. TP309H	A 240 Gr. 309H		

**NOTES:**

- (1) At temperatures over 1000°F, use only when the carbon content is 0.04% or higher.
- (2) For temperatures above 1000°F, use only if the material is solution heat treated to the minimum temperature specified in the material specification but not lower than 1900°F and quenching in water or rapidly cooling by other means.
- (3) This material should be used for service temperatures 1050°F and above only when assurance is provided that grain size is not finer than ASTM 6.

**TABLE 2-2.6B SPECIAL CLASS**

Temperature, °F	Working Pressures by Classes, psig							
	150	300	400	600	900	1500	2500	4500
-20 to 100	265	695	925	1,390	2,085	3,470	5,785	10,415
200	245	640	850	1,280	1,915	3,195	5,320	9,580
300	235	610	810	1,220	1,825	3,045	5,070	9,130
400	225	590	785	1,175	1,760	2,935	4,895	8,810
500	215	560	750	1,125	1,685	2,810	4,680	8,420
600	205	535	710	1,065	1,600	2,665	4,445	7,995
650	200	520	695	1,040	1,560	2,600	4,330	7,795
700	195	505	675	1,010	1,520	2,530	4,215	7,585
750	190	500	665	995	1,495	2,490	4,150	7,475
800	185	485	645	970	1,455	2,420	4,035	7,265
850	180	475	635	950	1,425	2,370	3,950	7,110
900	180	465	620	925	1,390	2,315	3,860	6,945
950	175	450	600	900	1,350	2,250	3,750	6,750
1000	160	420	560	840	1,260	2,100	3,500	6,300
1050	140	365	485	730	1,095	1,820	3,035	5,465
1100	105	280	370	560	835	1,395	2,320	4,180
1150	85	215	285	430	645	1,070	1,785	3,215
1200	60	165	215	325	490	815	1,355	2,445
1250	50	125	165	250	375	620	1,035	1,865
1300	40	100	130	200	295	495	820	1,480
1350	30	75	100	145	220	365	610	1,095
1400	20	55	75	110	170	280	465	835
1450	15	40	50	75	115	195	320	580
1500	10	30	40	60	90	150	250	450

**TABLE 2-2.7**  
**RATINGS FOR GROUP 2.7 MATERIALS**

A 182 Gr. F310H	A 312 Gr. TP310H	A 358 Gr. 310H	A 479 Gr. 310S (1)(2)(3)
A 240 Gr. 310S (1)(2)(3)	A 351 Gr. CK20 (1)		
A 240 Gr. 310H	A 479 Gr. 310H		

**NOTES:**

- (1) At temperatures over 1000°F, use only when the carbon content is 0.04% or higher.
- (2) For temperatures above 1000°F, use only if the material is solution heat treated to the minimum temperature specified in the material specification but not lower than 1900°F and quenching in water or rapidly cooling by other means.
- (3) Service temperatures of 1050°F and above should be used only when assurance is provided that grain size is not finer than ASTM 6.

**TABLE 2-2.7A STANDARD CLASS**

Temperature, °F	Working Pressures by Classes, psig							
	150	300	400	600	900	1500	2500	4500
-20 to 100	260	670	895	1,345	2,015	3,360	5,600	10,080
200	235	605	810	1,215	1,820	3,035	5,060	9,110
300	220	570	760	1,140	1,705	2,845	4,740	8,530
400	200	535	715	1,070	1,605	2,675	4,460	8,030
500	170	505	675	1,015	1,520	2,530	4,220	7,595
600	140	480	640	960	1,440	2,400	4,000	7,200
650	125	470	625	935	1,405	2,340	3,900	7,020
700	110	455	610	910	1,370	2,280	3,800	6,840
750	95	450	600	900	1,345	2,245	3,740	6,730
800	80	435	580	875	1,310	2,185	3,640	6,550
850	65	425	570	855	1,280	2,135	3,560	6,410
900	50	420	555	835	1,255	2,090	3,480	6,265
950	35	385	515	775	1,160	1,930	3,220	5,795
1000	20	345	460	685	1,030	1,720	2,865	5,155
1050	20(1)	335	450	670	1,010	1,680	2,800	5,040
1100	20(1)	260	345	520	780	1,305	2,170	3,910
1150	20(1)	190	250	375	565	945	1,570	2,830
1200	20(1)	135	185	275	410	685	1,145	2,055
1250	20(1)	105	135	205	310	515	855	1,545
1300	20(1)	75	100	150	225	375	630	1,130
1350	20(1)	60	80	115	175	290	485	875
1400	20(1)	45	60	90	135	225	370	670
1450	10(1)	35	45	65	100	165	275	500
1500	10(1)	25	35	50	75	130	215	385

**NOTE:**

- (1) For welding end valves only. Flanged end ratings terminate at 1000°F.

VALVES — FLANGED,  
THREADED, AND WELDING END

ASME B16.34a-1998

**TABLE 2-2.7 (CONT'D)  
RATINGS FOR GROUP 2.7 MATERIALS**

A 182 Gr. F310H	A 312 Gr. TP310H	A 358 Gr. 310H	A 479 Gr. 310S (1)(2)(3)
A 240 Gr. 310S (1)(2)(3)	A 351 Gr. CK20 (1)		
A 240 Gr. 310H	A 479 Gr. 310H		

**NOTES:**

- (1) At temperatures over 1000°F, use only when the carbon content is 0.04% or higher.
- (2) For temperatures above 1000°F, use only if the material is solution heat treated to the minimum temperature specified in the material specification but not lower than 1900°F and quenching in water or rapidly cooling by other means.
- (3) Service temperatures of 1050°F and above should be used only when assurance is provided that grain size is not finer than ASTM 6.

**TABLE 2-2.7B SPECIAL CLASS**

Temperature, °F	Working Pressures by Classes, psig							
	150	300	400	600	900	1500	2500	4500
-20 to 100	270	700	930	1,395	2,095	3,495	5,820	10,480
200	245	640	850	1,275	1,915	3,195	5,320	9,580
300	235	610	810	1,215	1,825	3,045	5,070	9,130
400	225	590	790	1,185	1,775	2,955	4,930	8,870
500	215	565	755	1,130	1,695	2,825	4,710	8,480
600	205	535	715	1,070	1,605	2,680	4,465	8,035
650	200	520	695	1,045	1,565	2,610	4,355	7,835
700	195	510	680	1,020	1,525	2,545	4,240	7,635
750	190	500	670	1,000	1,505	2,505	4,175	7,515
800	185	490	650	975	1,465	2,440	4,065	7,315
850	180	475	635	950	1,425	2,380	3,965	7,135
900	180	465	620	930	1,400	2,330	3,885	6,990
950	175	455	605	910	1,365	2,270	3,785	6,815
1000	160	420	560	840	1,260	2,105	3,505	6,310
1050	160	420	560	840	1,260	2,100	3,500	6,300
1100	125	325	435	650	975	1,630	2,715	4,885
1150	90	235	315	470	705	1,180	1,965	3,535
1200	65	170	230	345	515	855	1,430	2,570
1250	50	130	170	255	385	645	1,070	1,930
1300	35	95	125	190	285	470	785	1,415
1350	30	75	95	145	220	365	605	1,095
1400	20	55	75	110	165	280	465	835
1450	15	40	55	85	125	210	345	625
1500	10	30	45	65	95	160	270	480

(a)

**TABLE 2-2.8  
RATINGS FOR GROUP 2.8 MATERIALS**

A 182 Gr. F44		A 182 Gr. F53 (1)	A 240 Gr. S31254	A 351 Gr. CK3MCuN
A 182 Gr. F51 (1)	A 182 Gr. S32760 (1)	A 240 Gr. S31803 (1)	A 240 Gr. S32750 (1)	A 351 Gr. CE8MN (1)
A 479 Gr. S31254	A 240 Gr. S32760 (1)	A 479 Gr. S31803 (1)	A 479 Gr. S32750 (1)	A 351 Gr. CD4MCu (1)
A 312 Gr. S31254	A 789 Gr. S32760 (1)	A 789 Gr. S31803 (1)	A 789 Gr. S32750 (1)	A 351 Gr. CD3MWCuN (1)
A 358 Gr. S31254	A 790 Gr. S32760 (1)	A 790 Gr. S31803 (1)	A 790 Gr. S52750 (1)	

NOTE:

(1) This steel may become brittle after service at moderately elevated temperatures. Not to be used over 600°F.

**TABLE 2-2.8A STANDARD CLASS**

Temperature, °F	Working Pressures by Classes, psig							
	150	300	400	600	900	1500	2500	4500
-20 to 100	290	750	1,000	1,500	2,250	3,750	6,250	11,250
200	260	720	960	1,440	2,160	3,600	6,000	10,800
300	230	665	885	1,330	1,995	3,325	5,540	9,970
400	200	615	820	1,230	1,845	3,070	5,120	9,215
500	170	575	770	1,150	1,730	2,880	4,800	8,640
600	140	555	740	1,115	1,670	2,785	4,640	8,350
650	125	550	735	1,100	1,650	2,750	4,580	8,245
700	110	540	725	1,085	1,625	2,710	4,520	8,135
750	95	530	710	1,065	1,595	2,660	4,430	7,970

**TABLE 2-2.8B SPECIAL CLASS**

Temperature, °F	Working Pressures by Classes, psig							
	150	300	400	600	900	1500	2500	4500
-20 to 100	290	750	1,000	1,500	2,250	3,750	6,250	11,250
200	290	750	1,000	1,500	2,250	3,750	6,250	11,250
300	285	740	990	1,485	2,225	3,710	6,185	11,130
400	265	685	915	1,370	2,055	3,430	5,715	10,285
500	245	645	855	1,285	1,930	3,215	5,355	9,645
600	240	620	830	1,245	1,865	3,105	5,180	9,320
650	235	615	820	1,225	1,840	3,065	5,110	9,200
700	230	605	805	1,210	1,815	3,025	5,045	9,080
750	230	595	795	1,195	1,790	2,985	4,980	8,960



VALVES — FLANGED,  
THREADED, AND WELDING END

ASME B16.34a-1998

**TABLE 2-3.1**  
**RATINGS FOR GROUP 3.1 MATERIALS**

(a)

	B 463 Gr. N08020 (1)	B 468 Gr. N08020 (1)	B 473 Gr. N08020 (1)
B 462 Gr. N08020 (1)	B 464 Gr. N08020 (1)		

NOTE:

(1) Use annealed material only.

**TABLE 2-3.1A STANDARD CLASS**

(a)

Temperature, °F	Working Pressures by Classes, psig							
	150	300	400	600	900	1500	2500	4500
-20 to 100	290	750	1,000	1,500	2,250	3,750	6,250	11,250
200	260	720	960	1,440	2,160	3,600	6,000	10,800
300	230	715	950	1,425	2,140	3,565	5,940	10,690
400	200	675	900	1,345	2,020	3,365	5,610	10,100
500	170	655	875	1,310	1,965	3,275	5,460	9,830
600	140	605	805	1,210	1,815	3,025	5,040	9,070
650	125	590	785	1,175	1,765	2,940	4,905	8,825
700	110	570	755	1,135	1,705	2,840	4,730	8,515
750	95	530	710	1,065	1,595	2,660	4,430	7,970
800	80	510	675	1,015	1,525	2,540	4,230	7,610

**TABLE 2-3.1B SPECIAL CLASS**

(a)

Temperature, °F	Working Pressures by Classes, psig							
	150	300	400	600	900	1500	2500	4500
-20 to 100	290	750	1,000	1,500	2,250	3,750	6,250	11,250
200	290	750	1,000	1,500	2,250	3,750	6,250	11,250
300	290	750	1,000	1,500	2,250	3,750	6,250	11,250
400	290	750	1,000	1,500	2,250	3,750	6,250	11,250
500	280	730	975	1,465	2,195	3,655	6,095	10,970
600	270	705	940	1,405	2,110	3,515	5,860	10,545
650	270	700	930	1,400	2,095	3,495	5,825	10,485
700	265	695	925	1,390	2,085	3,475	5,790	10,425
750	260	685	910	1,365	2,050	3,415	5,690	10,245
800	260	675	900	1,350	2,025	3,375	5,625	10,125

**TABLE 2-3.2  
RATINGS FOR GROUP 3.2 MATERIALS**

**B 160 Gr. N02200 (1)(2) B 161 Gr. N02200 (1) B 162 Gr. N02200 (1) B 163 Gr. N02200 (1)**

**NOTES:**

- (1) Use annealed material only.
- (2) For forgings, the chemical composition, mechanical properties, heat treating requirements, and grain size requirements shall conform to the applicable ASTM specification. The manufacturing procedures, tolerances, tests, certification, and markings shall be in accordance with ASTM B 564.

**TABLE 2-3.2A STANDARD CLASS**

Temperature, °F	Working Pressures by Classes, psig							
	150	300	400	600	900	1500	2500	4500
-20 to 100	140	360	480	720	1,080	1,800	3,000	5,400
200	140	360	480	720	1,080	1,800	3,000	5,400
300	140	360	480	720	1,080	1,800	3,000	5,400
400	140	360	480	720	1,080	1,800	3,000	5,400
500	140	360	480	720	1,080	1,800	3,000	5,400
600	140	360	480	720	1,080	1,800	3,000	5,400

**TABLE 2-3.2B SPECIAL CLASS**

Temperature, °F	Working Pressures by Classes, psig							
	150	300	400	600	900	1500	2500	4500
-20 to 100	155	400	535	805	1,205	2,010	3,350	6,025
200	155	400	535	805	1,205	2,010	3,350	6,025
300	155	400	535	805	1,205	2,010	3,350	6,025
400	155	400	535	805	1,205	2,010	3,350	6,025
500	155	400	535	805	1,205	2,010	3,350	6,025
600	155	400	535	805	1,205	2,010	3,350	6,025

VALVES — FLANGED,  
THREADED, AND WELDING END

ASME B16.34a-1998

**TABLE 2-3.3  
RATINGS FOR GROUP 3.3 MATERIALS**

B 160 Gr. N02201 (1)(2) B 162 Gr. N02201 (1)

**NOTES:**

- (1) Use annealed material only.
- (2) For forgings, the chemical composition, mechanical properties, heat treating requirements, and grain size requirements shall conform to the applicable ASTM specification. The manufacturing procedures, tolerances, tests, certification, and markings shall be in accordance with ASTM B 564.

**TABLE 2-3.3A STANDARD CLASS**

Temperature, °F	Working Pressures by Classes, psig							
	150	300	400	600	900	1500	2500	4500
-20 to 100	90	240	320	480	720	1,200	2,000	3,600
200	85	230	305	455	685	1,140	1,900	3,420
300	85	225	300	445	670	1,115	1,860	3,350
400	85	215	290	430	650	1,080	1,800	3,240
500	85	215	290	430	650	1,080	1,800	3,240
600	85	215	290	430	650	1,080	1,800	3,240
650	85	215	290	430	650	1,080	1,800	3,240
700	85	215	290	430	650	1,080	1,800	3,240
750	80	210	280	420	635	1,055	1,760	3,170
800	80	205	270	410	610	1,020	1,700	3,060
850	65	205	270	410	610	1,020	1,700	3,060
900	50	140	185	280	415	695	1,155	2,085
950	35	115	150	230	345	570	950	1,715
1000	20	95	125	185	280	465	770	1,390
1050	20(1)	75	100	150	220	370	615	1,100
1100	20(1)	60	80	125	185	310	515	925
1150	20(1)	45	60	95	140	230	385	695
1200	15(1)	35	50	75	110	185	310	555

**NOTE:**

- (1) For welding end valves only. Flanged end ratings terminate at 1000°F.

**TABLE 2-3.3 (CONT'D)  
RATINGS FOR GROUP 3.3 MATERIALS**

B 160 Gr. N02201 (1)(2) B 162 Gr. N02201 (1)

**NOTES:**

- (1) Use annealed material only.
- (2) For forgings, the chemical composition, mechanical properties, heat treating requirements, and grain size requirements shall conform to the applicable ASTM specification. The manufacturing procedures, tolerances, tests, certification, and markings shall be in accordance with ASTM B 564.

**(a) TABLE 2-3.3B SPECIAL CLASS**

Temperature, °F	Working Pressures by Classes, psig							
	150	300	400	600	900	1500	2500	4500
-20 to 100	105	270	355	535	805	1,340	2,230	4,020
200	100	255	340	510	765	1,270	2,120	3,815
300	95	250	330	500	745	1,245	2,075	3,735
400	90	240	320	480	725	1,205	2,010	3,615
500	90	240	320	480	725	1,205	2,010	3,615
600	90	240	320	480	725	1,205	2,010	3,615
650	90	240	320	480	725	1,205	2,010	3,615
700	90	240	320	480	725	1,205	2,010	3,615
750	90	235	315	470	705	1,180	1,965	3,535
800	85	230	305	455	685	1,140	1,895	3,415
850	85	230	305	455	685	1,140	1,895	3,415
900	70	180	240	360	540	905	1,505	2,710
950	55	150	200	295	445	745	1,240	2,230
1000	45	120	160	240	360	605	1,005	1,810
1050	35	95	130	195	290	480	805	1,445
1100	30	80	105	160	240	400	670	1,205
1150	25	60	80	120	180	300	500	905
1200	20	50	65	95	145	240	400	725

VALVES — FLANGED,  
THREADED, AND WELDING END

ASME B16.34a-1998

**TABLE 2-3.4  
RATINGS FOR GROUP 3.4 MATERIALS**

B 127 Gr. N04400 (1)	B 164 Gr. N04400 (1)	B 165 Gr. N04400 (1)	B 564 Gr. N04400 (1)
B 163 Gr. N04400 (1)	B 164 Gr. N04405 (1)(2)		

NOTES:

- (1) Use annealed material only.
- (2) For forgings, the chemical composition, mechanical properties, heat treating requirements, and grain size requirements shall conform to the applicable ASTM specification. The manufacturing procedures, tolerances, tests, certification, and markings shall be in accordance with ASTM B 564.

**TABLE 2-3.4A STANDARD CLASS**

Temperature, °F	Working Pressures by Classes, psig							
	150	300	400	600	900	1500	2500	4500
-20 to 100	230	600	800	1,200	1,800	3,000	5,000	9,000
200	200	530	705	1,055	1,585	2,640	4,400	7,920
300	190	495	660	990	1,485	2,470	4,120	7,415
400	185	480	635	955	1,435	2,390	3,980	7,165
500	170	475	635	950	1,435	2,375	3,960	7,130
600	140	475	635	950	1,435	2,375	3,960	7,130
650	125	475	635	950	1,435	2,375	3,960	7,130
700	110	475	635	950	1,435	2,375	3,960	7,130
750	95	470	625	935	1,405	2,340	3,900	7,020
800	80	460	610	915	1,375	2,290	3,820	6,875
850	65	340	455	680	1,020	1,695	2,830	5,090
900	50	245	330	495	740	1,235	2,055	3,705

**TABLE 2-3.4B SPECIAL CLASS**

Temperature, °F	Working Pressures by Classes, psig							
	150	300	400	600	900	1500	2500	4500
-20 to 100	255	670	895	1,340	2,010	3,350	5,580	10,045
200	225	590	785	1,180	1,770	2,945	4,910	8,840
300	210	550	735	1,100	1,650	2,755	4,590	8,260
400	205	535	710	1,065	1,600	2,665	4,440	7,995
500	205	530	710	1,060	1,590	2,650	4,420	7,955
600	205	530	710	1,060	1,590	2,650	4,420	7,955
650	205	530	710	1,060	1,590	2,650	4,420	7,955
700	205	530	710	1,060	1,590	2,650	4,420	7,955
750	200	520	695	1,045	1,565	2,610	4,355	7,835
800	195	510	680	1,025	1,535	2,560	4,265	7,675
850	170	440	590	885	1,325	2,210	3,685	6,630
900	125	320	430	645	965	1,605	2,680	4,820

**TABLE 2-3.5  
RATINGS FOR GROUP 3.5 MATERIALS**

B 163 Gr. N06600 (1)    B 167 Gr. N06600 (1)    B 168 Gr. N06600 (1)    B 564 Gr. N06600 (1)  
B 166 Gr. N06600 (1)

NOTE:  
(1) Use annealed material only.

(a) **TABLE 2-3.5A STANDARD CLASS**

Temperature, °F	Working Pressures by Classes, psig							
	150	300	400	600	900	1500	2500	4500
-20 to 100	290	750	1,000	1,500	2,250	3,750	6,250	11,250
200	260	750	1,000	1,500	2,250	3,750	6,250	11,250
300	230	730	970	1,455	2,185	3,640	6,070	10,925
400	200	705	940	1,410	2,115	3,530	5,880	10,585
500	170	665	885	1,330	1,995	3,325	5,540	9,965
600	140	605	805	1,210	1,815	3,025	5,040	9,070
650	125	590	785	1,175	1,765	2,940	4,905	8,825
700	110	570	755	1,135	1,705	2,840	4,730	8,515
750	95	530	710	1,065	1,595	2,660	4,430	7,970
800	80	510	675	1,015	1,525	2,540	4,230	7,610
850	65	485	650	975	1,460	2,435	4,060	7,305
900	50	450	600	900	1,350	2,245	3,745	6,740
950	35	325	435	655	980	1,635	2,725	4,905
1000	20	215	290	430	650	1,080	1,800	3,240
1050	20(1)	140	185	280	415	695	1,155	2,085
1100	20(1)	95	125	185	280	465	770	1,390
1150	20(1)	70	90	135	205	340	565	1,020
1200	20(1)	60	80	125	185	310	515	925

NOTE:  
(1) For welding end valves only. Flanged end ratings terminate at 1000°F.

**TABLE 2-3.5B SPECIAL CLASS**

Temperature, °F	Working Pressures by Classes, psig							
	150	300	400	600	900	1500	2500	4500
-20 to 100	290	750	1,000	1,500	2,250	3,750	6,250	11,250
200	290	750	1,000	1,500	2,250	3,750	6,250	11,250
300	290	750	1,000	1,500	2,250	3,750	6,250	11,250
400	290	750	1,000	1,500	2,250	3,750	6,250	11,250
500	290	750	1,000	1,500	2,250	3,750	6,250	11,250
600	285	745	995	1,495	2,240	3,735	6,230	11,210
650	280	735	980	1,470	2,200	3,670	6,115	11,010
700	275	725	965	1,445	2,170	3,615	6,025	10,850
750	270	710	945	1,420	2,130	3,550	5,915	10,645
800	270	700	930	1,400	2,095	3,495	5,825	10,485
850	260	680	905	1,355	2,030	3,385	5,645	10,160
900	230	600	800	1,200	1,800	3,000	5,000	9,000
950	165	425	570	850	1,280	2,130	3,550	6,390
1000	110	280	375	565	845	1,405	2,345	4,220
1050	70	180	240	360	540	905	1,505	2,710
1100	45	120	160	240	360	605	1,005	1,810
1150	35	90	120	175	265	440	735	1,325
1200	30	80	105	160	240	400	670	1,205

VALVES — FLANGED  
THREADED, AND WELDING END

ASME B16.34-1996

**TABLE 2-3.6  
RATINGS FOR GROUP 3.6 MATERIALS**

B 163 Gr. N08800 (1)    B 408 Gr. N08800 (1)    B 409 Gr. N08800 (1)    B 564 Gr. N08800 (1)

NOTE:

(1) Use annealed material only.

**TABLE 2-3.6A    STANDARD CLASS**

Temperature, °F	Working Pressures by Classes, psig							
	150	300	400	600	900	1500	2500	4500
-20 to 100	275	720	960	1,440	2,160	3,600	6,000	10,800
200	255	660	885	1,325	1,990	3,310	5,520	9,935
300	230	625	830	1,250	1,870	3,120	5,200	9,360
400	200	600	800	1,200	1,800	3,000	5,000	9,000
500	170	580	770	1,155	1,735	2,890	4,820	8,875
600	140	575	765	1,145	1,720	2,870	4,780	8,605
650	125	570	760	1,140	1,705	2,845	4,740	8,530
700	110	565	750	1,130	1,690	2,820	4,700	8,460
750	95	530	710	1,065	1,595	2,660	4,430	7,970
800	80	505	675	1,015	1,520	2,535	4,230	7,610
850	65	485	650	975	1,460	2,435	4,060	7,305
900	50	450	600	900	1,350	2,245	3,745	6,740
950	35	385	515	775	1,160	1,930	3,220	5,795
1000	20	365	485	725	1,090	1,820	3,030	5,450
1050	20(1)	360	480	720	1,080	1,800	3,000	5,400
1100	20(1)	325	430	645	965	1,610	2,685	4,835
1150	20(1)	275	365	550	825	1,370	2,285	4,115
1200	20(1)	205	270	405	610	1,020	1,695	3,055
1250	20(1)	130	175	260	390	650	1,080	1,945
1300	20(1)	60	80	125	185	310	515	925
1350	20(1)	50	65	100	150	245	410	740
1400	15(1)	35	45	70	100	170	285	510
1450	10(1)	30	40	60	95	155	255	465
1500	10(1)	25	35	50	75	125	205	370

NOTE:

(1) For welding end valves only. Flanged end ratings terminate at 1000°F.

**TABLE 2-3.6 (CONT'D)  
RATINGS FOR GROUP 3.6 MATERIALS**

B 163 Gr. N08800 (1)    B 408 Gr. N08800 (1)    B 409 Gr. N08800 (1)    B 564 Gr. N08800 (1)

**NOTE:**

(1) Use annealed material only.

**TABLE 2-3.6B SPECIAL CLASS**

Temperature, °F	Working Pressures by Classes, psig							
	150	300	400	600	900	1500	2500	4500
-20 to 100	290	750	1,000	1,500	2,250	3,750	6,250	11,250
200	285	740	985	1,480	2,220	3,695	6,160	11,090
300	265	695	930	1,395	2,090	3,480	5,805	10,445
400	255	670	895	1,340	2,010	3,350	5,580	10,045
500	245	645	860	1,290	1,935	3,230	5,380	9,685
600	245	640	855	1,280	1,920	3,200	5,335	9,605
650	245	635	845	1,270	1,905	3,175	5,290	9,520
700	240	630	840	1,260	1,890	3,145	5,245	9,440
750	240	625	830	1,250	1,870	3,120	5,200	9,360
800	235	615	820	1,230	1,850	3,080	5,135	9,240
850	235	615	820	1,230	1,845	3,075	5,125	9,220
900	230	600	800	1,200	1,800	3,000	5,000	9,000
950	180	470	630	945	1,415	2,360	3,930	7,070
1000	160	420	560	840	1,260	2,105	3,505	6,310
1050	160	420	560	840	1,260	2,105	3,505	6,310
1100	155	405	540	805	1,210	2,015	3,360	6,045
1150	130	345	460	685	1,030	1,715	2,860	5,145
1200	100	260	345	515	770	1,285	2,145	3,860
1250	65	170	225	335	505	845	1,405	2,530
1300	30	80	105	160	240	400	670	1,205
1350	25	65	85	130	195	320	535	965
1400	15	45	60	90	135	220	370	665
1450	15	40	55	80	120	200	335	605
1500	10	30	45	65	95	160	270	480



VALVES – FLANGED,  
THREADED, AND WELDING END

ASME B16.34a-1998

**TABLE 2-3.7  
RATINGS FOR GROUP 3.7 MATERIALS**

B 333 Gr. N10665 (1) B 335 Gr. N10665 (1)(2) B 622 Gr. N10665 (1)

**NOTES:**

- (1) Use solution annealed material only.
- (2) For forgings, the chemical composition, mechanical properties, heat treating requirements, and grain size requirements shall conform to the applicable ASTM specification. The manufacturing procedures, tolerances, tests, certification, and markings shall be in accordance with ASTM B564.

**TABLE 2-3.7A STANDARD CLASS**

Temperature, °F	Working Pressures by Classes, psig							
	150	300	400	600	900	1500	2500	4500
-20 to 100	290	750	1,000	1,500	2,250	3,750	6,250	11,250
200	260	750	1,000	1,500	2,250	3,750	6,250	11,250
300	230	730	970	1,455	2,185	3,640	6,070	10,925
400	200	705	940	1,410	2,115	3,530	5,880	10,585
500	170	665	885	1,330	1,995	3,325	5,540	9,965
600	140	605	805	1,210	1,815	3,025	5,040	9,070
650	125	590	785	1,175	1,765	2,940	4,905	8,825
700	110	570	755	1,135	1,705	2,840	4,730	8,515
750	95	530	710	1,065	1,595	2,660	4,430	7,970
800	80	510	675	1,015	1,525	2,540	4,230	7,610

**TABLE 2-3.7B SPECIAL CLASS**

(a)

Temperature, °F	Working Pressures by Classes, psig							
	150	300	400	600	900	1500	2500	4500
-20 to 100	290	750	1,000	1,500	2,250	3,750	6,250	11,250
200	290	750	1,000	1,500	2,250	3,750	6,250	11,250
300	290	750	1,000	1,500	2,250	3,750	6,250	11,250
400	290	750	1,000	1,500	2,250	3,750	6,250	11,250
500	290	750	1,000	1,500	2,250	3,750	6,250	11,250
600	290	750	1,000	1,500	2,250	3,750	6,250	11,250
650	290	750	1,000	1,500	2,250	3,750	6,250	11,250
700	280	735	980	1,465	2,200	3,665	6,110	10,995
750	280	730	970	1,460	2,185	3,645	6,070	10,930
800	275	720	960	1,440	2,160	3,600	6,000	10,800

**TABLE 2-3.8**  
**RATINGS FOR GROUP 3.8 MATERIALS**

B 333 Gr. N10001 (1)(6)	B 434 Gr. N10003 (3)	B 564 Gr. N10276 (1)(4)	B 575 Gr. N10276 (1)(4)
B 335 Gr. N10001 (1)(2)(6)	B 443 Gr. N06625 (3)(5)	B 573 Gr. N10003 (2)(3)	B 622 Gr. N06455 (1)(6)
B 423 Gr. N08825 (3)(7)	B 446 Gr. N06625 (3)(5)	B 574 Gr. N06455 (1)(2)(6)	B 622 Gr. N10001 (3)(6)
B 424 Gr. N08825 (3)(7)	B 564 Gr. N06625 (3)(5)	B 574 Gr. N10276 (1)(2)(4)	B 622 Gr. N10276 (1)(4)
B 425 Gr. N08825 (2)(3)(7)	B 564 Gr. N08825 (3)(7)	B 575 Gr. N06455 (1)(6)	

**NOTES:**

- (1) Use solution annealed material only.
- (2) For forgings, the chemical composition, mechanical properties, heat treating requirements, and grain size requirements shall conform to the applicable ASTM specification. The manufacturing procedures, tolerances, tests, certification, and markings shall be in accordance with ASTM B 564.
- (3) Use annealed material only.
- (4) Not to be used over 1250°F.
- (5) Not to be used over 1200°F. Alloy N06625 in the annealed condition is subject to severe loss of impact strength at room temperatures after exposure in the range of 1000°F to 1400°F.
- (6) Not to be used over 800°F.
- (7) Not to be used over 1000°F.

**TABLE 2-3.8A STANDARD CLASS**

Temperature, °F	Working Pressures by Classes, psig							
	150	300	400	600	900	1500	2500	4500
-20 to 100	290	750	1,000	1,500	2,250	3,750	6,250	11,250
200	260	750	1,000	1,500	2,250	3,750	6,250	11,250
300	230	730	970	1,455	2,185	3,640	6,070	10,925
400	200	705	940	1,410	2,115	3,530	5,880	10,585
500	170	665	885	1,330	1,995	3,325	5,540	9,965
600	140	605	805	1,210	1,815	3,025	5,040	9,070
650	125	590	785	1,175	1,765	2,940	4,905	8,825
700	110	570	755	1,135	1,705	2,840	4,730	8,515
750	95	530	710	1,065	1,595	2,660	4,430	7,970
800	80	510	675	1,015	1,525	2,540	4,230	7,610
850	65	485	650	975	1,460	2,435	4,060	7,305
900	50	450	600	900	1,350	2,245	3,745	6,740
950	35	385	515	775	1,160	1,930	3,220	5,795
1000	20	365	485	725	1,090	1,820	3,030	5,450
1050	20(1)	360	480	720	1,080	1,800	3,000	5,400
1100	20(1)	325	430	645	965	1,610	2,685	4,835
1150	20(1)	275	365	550	825	1,370	2,285	4,115
1200	20(1)	185	245	370	555	925	1,545	2,775
1250	20(1)	145	195	295	440	735	1,220	2,200
1300	20(1)	110	145	215	325	540	900	1,620

**NOTE:**

- (1) For welding end valves only. Flanged end ratings terminate at 1000°F.

VALVES — FLANGED  
 THREADED, AND WELDING END

ASME B16.34-1996

**TABLE 2-3.8 (CONT'D)  
 RATINGS FOR GROUP 3.8 MATERIALS**

B 333 Gr. N10001 (1)(6)	B 434 Gr. N10003 (3)	B 564 Gr. N10276 (1)(4)	B 575 Gr. N10276 (1)(4)
B 335 Gr. N10001 (1)(2)(6)	B 443 Gr. N06625 (3)(5)	B 573 Gr. N10003 (2)(3)	B 622 Gr. N06455 (1)(6)
B 423 Gr. N08825 (3)(7)	B 446 Gr. N06625 (3)(5)	B 574 Gr. N06455 (1)(2)(6)	B 622 Gr. N10001 (3)(6)
B 424 Gr. N08825 (3)(7)	B 564 Gr. N06625 (3)(5)	B 574 Gr. N10276 (1)(2)(4)	B 622 Gr. N10276 (1)(4)
B 425 Gr. N08825 (2)(3)(7)	B 564 Gr. N08825 (3)(7)	B 575 Gr. N06455 (1)(6)	

**NOTES:**

- (1) Use solution annealed material only.
- (2) For forgings, the chemical composition, mechanical properties, heat treating requirements, and grain size requirements shall conform to the applicable ASTM specification. The manufacturing procedures, tolerances, tests, certification, and markings shall be in accordance with ASTM B 564.
- (3) Use annealed material only.
- (4) Not to be used over 1250°F.
- (5) Not to be used over 1200°F. Alloy N06625 in the annealed condition is subject to severe loss of impact strength at room temperatures after exposure in the range of 1000°F to 1400°F.
- (6) Not to be used over 800°F.
- (7) Not to be used over 1000°F.

**TABLE 2-3.8B SPECIAL CLASS**

Temperature, °F	Working Pressures by Classes, psig							
	150	300	400	600	900	1500	2500	4500
-20 to 100	290	750	1,000	1,500	2,250	3,750	6,250	11,250
200	290	750	1,000	1,500	2,250	3,750	6,250	11,250
300	290	750	1,000	1,500	2,250	3,750	6,250	11,250
400	290	750	1,000	1,500	2,250	3,750	6,250	11,250
500	285	740	990	1,485	2,225	3,710	6,185	11,130
600	275	725	965	1,445	2,170	3,615	6,025	10,850
650	270	710	945	1,420	2,130	3,550	5,915	10,645
700	265	695	930	1,395	2,090	3,480	5,805	10,445
750	265	690	920	1,380	2,075	3,455	5,760	10,365
800	265	685	915	1,370	2,055	3,430	5,715	10,285
850	260	675	900	1,350	2,025	3,375	5,625	10,125
900	230	600	800	1,200	1,800	3,000	5,000	9,000
950	180	470	630	945	1,415	2,360	3,930	7,070
1000	160	420	560	840	1,260	2,105	3,505	6,310
1050	160	420	560	840	1,260	2,105	3,505	6,310
1100	155	405	540	805	1,210	2,015	3,360	6,045
1150	130	345	460	685	1,030	1,715	2,860	5,145
1200	90	240	320	480	725	1,205	2,010	3,615
1250	75	190	255	380	575	955	1,590	2,865
1300	55	140	190	280	420	705	1,170	2,110

**TABLE 2-3.9  
RATINGS FOR GROUP 3.9 MATERIALS**

B 435 Gr. N06002 (1)    B 572 Gr. N06002 (1)(2)    B 622 Gr. N06002 (1)

**NOTES:**

- (1) Use solution annealed material only.
- (2) For forgings, the chemical composition, mechanical properties, heat treating requirements, and grain size requirements shall conform to the applicable ASTM specification. The manufacturing procedures, tolerances, tests, certification, and markings shall be in accordance with ASTM B 564.

**TABLE 2-3.9A STANDARD CLASS**

Temperature, °F	Working Pressures by Classes, psig							
	150	300	400	600	900	1500	2500	4500
-20 to 100	290	750	1,000	1,500	2,250	3,750	6,250	11,250
200	260	750	1,000	1,500	2,250	3,750	6,250	11,250
300	230	680	905	1,360	2,040	3,395	5,660	10,190
400	200	600	795	1,195	1,795	2,990	4,980	8,965
500	170	575	770	1,150	1,730	2,880	4,800	8,640
600	140	560	745	1,120	1,680	2,795	4,660	8,390
650	125	560	745	1,120	1,680	2,795	4,660	8,390
700	110	560	745	1,120	1,680	2,795	4,660	8,390
750	95	530	710	1,065	1,595	2,660	4,430	7,970
800	80	510	675	1,015	1,525	2,540	4,230	7,610
850	65	485	650	975	1,460	2,435	4,060	7,305
900	50	450	600	900	1,350	2,245	3,745	6,740
950	35	385	515	775	1,160	1,930	3,220	5,795
1000	20	365	485	725	1,090	1,820	3,030	5,450
1050	20(1)	360	480	720	1,080	1,800	3,000	5,400
1100	20(1)	325	430	645	965	1,610	2,685	4,835
1150	20(1)	275	365	550	825	1,370	2,285	4,115
1200	20(1)	205	275	410	620	1,030	1,715	3,085
1250	20(1)	180	245	365	545	910	1,515	2,725
1300	20(1)	140	185	275	410	685	1,145	2,060
1350	20(1)	105	140	205	310	515	860	1,545
1400	20(1)	75	100	150	225	380	630	1,130
1450	20(1)	60	80	115	175	290	485	875
1500	20(1)	40	55	85	125	205	345	620

**NOTE:**

- (1) For welding end valves only. Flanged end ratings terminate at 1000°F.

VALVES — FLANGED,  
THREADED, AND WELDING END

ASME B16.34a-1998

**TABLE 2-3.9 (CONT'D)  
RATINGS FOR GROUP 3.9 MATERIALS**

B 435 Gr. N06002 (1) B 572 Gr. N06002 (1)(2) B 622 Gr. N06002 (1)

NOTES:

- (1) Use solution annealed material only.
- (2) For forgings, the chemical composition, mechanical properties, heat treating requirements, and grain size requirements shall conform to the applicable ASTM specification. The manufacturing procedures, tolerances, tests, certification, and markings shall be in accordance with ASTM B 564.

**TABLE 2-3.9B SPECIAL CLASS**

(a)

Temperature, °F	Working Pressures by Classes, psig							
	150	300	400	600	900	1500	2500	4500
-20 to 100	290	750	1,000	1,500	2,250	3,750	6,250	11,250
200	290	750	1,000	1,500	2,250	3,750	6,250	11,250
300	290	750	1,000	1,500	2,250	3,750	6,250	11,250
400	255	665	890	1,335	2,000	3,335	5,560	10,005
500	245	645	855	1,285	1,930	3,215	5,355	9,645
600	240	625	830	1,250	1,870	3,120	5,200	9,360
650	240	625	830	1,250	1,870	3,120	5,200	9,360
700	240	625	830	1,250	1,870	3,120	5,200	9,360
750	240	625	830	1,250	1,870	3,120	5,200	9,360
800	240	625	830	1,250	1,870	3,120	5,200	9,360
850	225	585	780	1,175	1,760	2,935	4,890	8,800
900	225	585	775	1,165	1,750	2,915	4,855	8,740
950	180	470	630	945	1,415	2,360	3,930	7,070
1000	160	420	560	840	1,260	2,105	3,505	6,310
1050	160	420	560	840	1,260	2,105	3,505	6,310
1100	155	405	540	805	1,210	2,015	3,360	6,045
1150	130	345	460	685	1,030	1,715	2,860	5,145
1200	100	260	345	515	770	1,285	2,145	3,860
1250	90	230	305	455	680	1,135	1,895	3,410
1300	65	170	230	345	515	860	1,430	2,570
1350	50	130	170	260	385	645	1,070	1,930
1400	35	95	125	190	285	470	785	1,415
1450	30	75	100	145	220	365	610	1,095
1500	20	50	70	105	155	260	430	770

**TABLE 2-3.10  
RATINGS FOR GROUP 3.10 MATERIALS**

B 599 Gr. N08700 (1)    B 672 Gr. N08700 (1)(2)

**NOTES:**

- (1) Use solution annealed material only.
- (2) For forgings, the chemical composition, mechanical properties, heat treating requirements, and grain size requirements shall conform to the applicable ASTM specification. The manufacturing procedures, tolerances, tests, certification, and markings shall be in accordance with ASTM B 564.

**TABLE 2-3.10A    STANDARD CLASS**

Temperature, °F	Working Pressures by Classes, psig							
	150	300	400	600	900	1500	2500	4500
-20 to 100	275	720	960	1,440	2,160	3,600	6,000	10,800
200	260	720	960	1,440	2,160	3,600	6,000	10,800
300	230	680	905	1,360	2,040	3,400	5,670	10,205
400	200	640	855	1,280	1,920	3,205	5,340	9,610
500	170	610	815	1,225	1,835	3,060	5,100	9,180
600	140	595	790	1,190	1,780	2,970	4,950	8,910
650	125	570	760	1,140	1,705	2,845	4,740	8,530

**TABLE 2-3.10B    SPECIAL CLASS**

Temperature, °F	Working Pressures by Classes, psig							
	150	300	400	600	900	1500	2500	4500
-20 to 100	290	750	1,000	1,500	2,250	3,750	6,250	11,250
200	290	750	1,000	1,500	2,250	3,750	6,250	11,250
300	290	750	1,000	1,500	2,250	3,750	6,250	11,250
400	275	715	955	1,430	2,145	3,575	5,960	10,730
500	260	685	910	1,365	2,050	3,415	5,690	10,245
600	255	665	885	1,325	1,990	3,315	5,525	9,945
650	245	635	845	1,270	1,905	3,175	5,290	9,520

VALVES – FLANGED,  
THREADED, AND WELDING END

ASME B16.34a-1998

**TABLE 2-3.11  
RATINGS FOR GROUP 3.11 MATERIALS**

B 625 Gr. N08904 (1)    B 649 Gr. N08904 (1)(2)    B 677 Gr. N08904 (1)

**NOTES:**

- (1) Use annealed material only.
- (2) For forgings, the chemical composition, mechanical properties, heat treating requirements, and grain size requirements shall conform to the applicable ASTM specification. The manufacturing procedures, tolerances, tests, certification, and markings shall be in accordance with ASTM B 564.

**TABLE 2-3.11A STANDARD CLASS**

Temperature, °F	Working Pressures by Classes, psig							
	150	300	400	600	900	1500	2500	4500
-20 to 100	245	640	855	1,280	1,920	3,205	5,340	9,610
200	230	600	800	1,200	1,805	3,005	5,010	9,020
300	210	545	725	1,085	1,630	2,720	4,530	8,155
400	190	495	660	995	1,490	2,485	4,140	7,450
500	170	455	610	915	1,370	2,285	3,810	6,860
600	140	430	575	865	1,295	2,160	3,600	6,480
650	125	420	560	840	1,265	2,105	3,510	6,320
700	110	410	545	820	1,230	2,050	3,420	6,155

**TABLE 2-3.11B SPECIAL CLASS**

(a)

Temperature, °F	Working Pressures by Classes, psig							
	150	300	400	600	900	1500	2500	4500
-20 to 100	275	715	955	1,430	2,145	3,575	5,960	10,730
200	255	670	895	1,340	2,015	3,355	5,590	10,065
300	235	605	810	1,215	1,820	3,035	5,055	9,100
400	215	555	740	1,110	1,665	2,770	4,620	8,315
500	195	510	680	1,020	1,530	2,550	4,250	7,655
600	185	480	645	965	1,445	2,410	4,020	7,230
650	180	470	625	940	1,410	2,350	3,915	7,050
700	175	460	610	915	1,375	2,290	3,815	6,870

**TABLE 2-3.12  
RATINGS FOR GROUP 3.12 MATERIALS**

B 581 Gr. N06985 (1)(2)	B 582 Gr. N06985 (1)	B 620 Gr. N08320 (1)	B 621 Gr. N08320 (1)(2)
B 622 Gr. N06985 (1)	B 622 Gr. N08320 (1)		

**NOTES:**

- (1) Use solution annealed material only.
- (2) For forgings, the chemical composition, mechanical properties, heat treating requirements, and grain size requirements shall conform to the applicable ASTM specification. The manufacturing procedures, tolerances, tests, certification, and markings shall be in accordance with ASTM B 564.

**TABLE 2-3.12A STANDARD CLASS**

Temperature, °F	Working Pressures by Classes, psig							
	150	300	400	600	900	1500	2500	4500
-20 to 100	260	670	895	1,345	2,015	3,360	5,600	10,080
200	240	625	830	1,245	1,870	3,115	5,190	9,340
300	225	585	780	1,175	1,760	2,935	4,890	8,800
400	200	535	715	1,075	1,610	2,680	4,470	8,045
500	170	500	665	1,000	1,500	2,500	4,170	7,505
600	140	475	635	950	1,425	2,375	3,960	7,130
650	125	465	620	930	1,395	2,320	3,870	6,965
700	110	450	600	900	1,350	2,250	3,750	6,750
750	95	445	590	885	1,330	2,215	3,690	6,640
800	80	430	575	865	1,295	2,160	3,600	6,480

**TABLE 2-3.12B SPECIAL CLASS**

Temperature, °F	Working Pressures by Classes, psig							
	150	300	400	600	900	1500	2500	4500
-20 to 100	290	750	1,000	1,500	2,250	3,750	6,250	11,250
200	265	695	925	1,390	2,085	3,475	5,790	10,425
300	250	655	875	1,310	1,965	3,275	5,460	9,825
400	230	600	800	1,195	1,795	2,995	4,990	8,980
500	215	560	745	1,115	1,675	2,790	4,655	8,375
600	205	530	705	1,060	1,590	2,650	4,420	7,955
650	200	520	690	1,035	1,555	2,590	4,320	7,775
700	195	500	670	1,005	1,505	2,510	4,185	7,535
750	190	495	660	990	1,485	2,470	4,120	7,415
800	185	480	645	965	1,445	2,410	4,020	7,230



VALVES — FLANGED  
THREADED, AND WELDING END

ASME B16.34-1996

**TABLE 2-3.13  
RATINGS FOR GROUP 3.13 MATERIALS**

B 564 Gr. N08031 (3)	B 581 Gr. N06975 (1)(2)	B 582 Gr. N06975 (1)	B 622 Gr. N06975 (1)
B 625 Gr. N08031 (3)	B 622 Gr. N08031 (3)	B 649 Gr. N08031 (3)	

**NOTES:**

- (1) Use solution annealed material only.
- (2) For forgings, the chemical composition, mechanical properties, heat treating requirements, and grain size requirements shall conform to the applicable ASTM specification. The manufacturing procedures, tolerances, tests, certification, and markings shall be in accordance with ASTM B 564.
- (3) Use annealed material only.

**TABLE 2-3.13A STANDARD CLASS**

Temperature, °F	Working Pressures by Classes, psig							
	150	300	400	600	900	1500	2500	4500
-20 to 100	290	750	1,000	1,500	2,250	3,750	6,250	11,250
200	260	705	940	1,410	2,115	3,530	5,880	10,585
300	230	660	885	1,325	1,985	3,310	5,520	9,935
400	200	635	845	1,265	1,900	3,170	5,280	9,505
500	170	595	790	1,190	1,780	2,970	4,950	8,910
600	140	560	750	1,125	1,685	2,810	4,680	8,425
650	125	555	735	1,105	1,660	2,765	4,605	8,290
700	110	545	725	1,085	1,630	2,720	4,530	8,155
750	95	530	710	1,065	1,595	2,660	4,430	7,970
800	80	510	675	1,015	1,525	2,540	4,230	7,610

**TABLE 2-3.13B SPECIAL CLASS**

Temperature, °F	Working Pressures by Classes, psig							
	150	300	400	600	900	1500	2500	4500
-20 to 100	290	750	1,000	1,500	2,250	3,750	6,250	11,250
200	290	750	1,000	1,500	2,250	3,750	6,250	11,250
300	285	740	985	1,480	2,220	3,695	6,160	11,090
400	270	705	945	1,415	2,120	3,535	5,895	10,605
500	255	665	885	1,325	1,990	3,315	5,525	9,945
600	240	625	835	1,255	1,880	3,135	5,225	9,400
650	235	615	820	1,235	1,850	3,085	5,140	9,250
700	235	605	810	1,215	1,820	3,035	5,055	9,100
750	230	600	800	1,195	1,795	2,995	4,990	8,980
800	225	590	790	1,180	1,770	2,955	4,920	8,860

**TABLE 2-3.14**  
**RATINGS FOR GROUP 3.14 MATERIALS**

B 581 Gr. N06007 (1)(2)    B 582 Gr. N06007 (1)    B 622 Gr. N06007 (1)

**NOTES:**

- (1) Use solution annealed material only.
- (2) For forgings, the chemical composition, mechanical properties, heat treating requirements, and grain size requirements shall conform to the applicable ASTM specification. The manufacturing procedures, tolerances, tests, certification, and markings shall be in accordance with ASTM B 564.

**TABLE 2-3.14A STANDARD CLASS**

Temperature, °F	Working Pressures by Classes, psig							
	150	300	400	600	900	1500	2500	4500
-20 to 100	275	720	960	1,440	2,160	3,600	6,000	10,800
200	245	645	860	1,290	1,935	3,230	5,380	9,685
300	230	600	795	1,195	1,795	2,990	4,980	8,965
400	200	560	750	1,125	1,685	2,810	4,680	8,425
500	170	535	715	1,070	1,605	2,675	4,460	8,030
600	140	520	690	1,035	1,555	2,590	4,320	7,775
650	125	510	680	1,020	1,535	2,555	4,260	7,670
700	110	505	675	1,015	1,520	2,530	4,220	7,595
750	95	500	670	1,005	1,505	2,510	4,180	7,525
800	80	495	660	995	1,490	2,485	4,140	7,450
850	65	485	650	975	1,460	2,435	4,060	7,305
900	50	450	600	900	1,350	2,245	3,745	6,740
950	35	385	515	775	1,160	1,930	3,220	5,795
1000	20	365	485	725	1,090	1,820	3,030	5,450

**TABLE 2-3.14B SPECIAL CLASS**

Temperature, °F	Working Pressures by Classes, psig							
	150	300	400	600	900	1500	2500	4500
-20 to 100	290	750	1,000	1,500	2,250	3,750	6,250	11,250
200	275	720	960	1,440	2,160	3,605	6,005	10,810
300	255	665	890	1,335	2,000	3,335	5,560	10,005
400	240	625	835	1,255	1,880	3,135	5,225	9,400
500	230	595	795	1,195	1,790	2,985	4,980	8,960
600	220	580	770	1,155	1,735	2,895	4,820	8,680
650	220	570	760	1,140	1,710	2,855	4,755	8,560
700	215	565	755	1,130	1,695	2,825	4,710	8,480
750	215	560	745	1,120	1,680	2,800	4,665	8,395
800	215	555	740	1,110	1,665	2,770	4,620	8,315
850	210	550	735	1,100	1,650	2,750	4,585	8,255
900	210	545	730	1,095	1,640	2,730	4,555	8,195
950	180	470	630	945	1,415	2,360	3,930	7,070
1000	160	420	560	840	1,260	2,105	3,505	6,310

VALVES — FLANGED,  
 THREADED, AND WELDING END

ASME B16.34a-1998

**TABLE 2-3.15  
 RATINGS FOR GROUP 3.15 MATERIALS**

B 407 Gr. N08810 (1)	B 408 Gr. N08810 (1)	B 409 Gr. N08810 (1)	B 564 Gr. N08810 (1)
A 494 Gr. N-12MV (1)(2)	A 494 Gr. CW-12MW (1)(2)		

**NOTES:**

- (1) Use solution annealed material only.
- (2) Not to be used over 1000°F.

**TABLE 2-3.15A STANDARD CLASS**

Temperature, °F	Working Pressures by Classes, psig							
	150	300	400	600	900	1500	2500	4500
-20 to 100	230	600	800	1,200	1,800	3,000	5,000	9,000
200	205	540	720	1,080	1,620	2,700	4,500	8,100
300	195	505	675	1,015	1,520	2,530	4,220	7,595
400	185	480	640	960	1,440	2,400	4,000	7,200
500	170	455	610	910	1,370	2,280	3,800	6,840
600	140	440	585	880	1,320	2,195	3,660	6,590
650	125	425	565	850	1,275	2,125	3,540	6,370
700	110	420	560	840	1,260	2,100	3,500	6,300
750	95	415	550	825	1,240	2,065	3,440	6,190
800	80	410	545	815	1,225	2,040	3,400	6,120
850	65	400	530	795	1,195	1,990	3,320	5,975
900	50	395	530	790	1,190	1,980	3,300	5,940
950	35	385	515	775	1,160	1,930	3,220	5,795
1000	20	365	485	725	1,090	1,820	3,030	5,450
1050	20(1)	325	435	650	975	1,625	2,710	4,875
1100	20(1)	320	430	640	965	1,605	2,675	4,815
1150	20(1)	275	365	550	825	1,370	2,285	4,115
1200	20(1)	205	275	410	620	1,030	1,715	3,085
1250	20(1)	180	245	365	545	910	1,515	2,725
1300	20(1)	140	185	275	410	685	1,145	2,060
1350	20(1)	105	140	205	310	515	860	1,545
1400	20(1)	75	100	150	225	380	630	1,130
1450	20(1)	60	80	115	175	290	485	875
1500	20(1)	40	55	85	125	205	345	620

**NOTE:**

- (1) For welding end valves only. Flanged end ratings terminate at 1000°F.

**TABLE 2-3.15 (CONT'D)  
RATINGS FOR GROUP 3.15 MATERIALS**

B 407 Gr. N08810 (1) B 408 Gr. N08810 (1) B 409 Gr. N08810 (1) B 564 Gr. N08810 (1)  
A 494 Gr. N-12MV (1)(2) A 494 Gr. CW-12MW (1)(2)

**NOTES:**

- (1) Use solution annealed material only.
- (2) Not to be used over 1000°F.

**(a) TABLE 2-3.15B SPECIAL CLASS**

Temperature, °F	Working Pressures by Classes, psig							
	150	300	400	600	900	1500	2500	4500
-20 to 100	255	670	895	1,340	2,010	3,350	5,580	10,045
200	230	605	805	1,205	1,810	3,015	5,020	9,040
300	215	565	755	1,130	1,695	2,825	4,710	8,480
400	205	535	715	1,070	1,605	2,680	4,465	8,035
500	195	510	680	1,020	1,525	2,545	4,240	7,635
600	190	490	655	980	1,470	2,450	4,085	7,355
650	180	475	630	950	1,420	2,370	3,950	7,110
700	180	470	625	940	1,405	2,345	3,905	7,030
750	175	460	615	920	1,380	2,305	3,840	6,910
800	175	455	605	910	1,365	2,275	3,795	6,830
850	170	445	595	890	1,335	2,225	3,705	6,670
900	170	440	590	885	1,325	2,210	3,685	6,630
950	165	435	580	870	1,300	2,170	3,615	6,510
1000	160	420	560	840	1,260	2,105	3,505	6,310
1050	160	420	560	840	1,260	2,105	3,505	6,310
1100	155	405	540	805	1,210	2,015	3,360	6,045
1150	130	345	460	685	1,030	1,715	2,860	5,145
1200	100	260	345	515	770	1,285	2,145	3,860
1250	90	230	305	455	680	1,135	1,895	3,410
1300	65	170	230	345	515	860	1,430	2,570
1350	50	130	170	260	385	645	1,070	1,930
1400	35	95	125	190	285	470	785	1,415
1450	30	75	100	145	220	365	610	1,095
1500	20	50	70	105	155	260	430	770

VALVES — FLANGED,  
THREADED, AND WELDING END

ASME B16.34a-1998

**TABLE 2-3.16  
RATINGS FOR GROUP 3.16 MATERIALS**

B 511 Gr. N08330 (1)(2) B 535 Gr. N08330 (1) B 536 Gr. N08330 (1)

**NOTES:**

- (1) Use solution annealed material only.
- (2) For forgings, the chemical composition, mechanical properties, heat treating requirements, and grain size requirements shall conform to the applicable ASTM specification. The manufacturing procedures, tolerances, tests, certification, and markings shall be in accordance with ASTM B 564.

(a) **TABLE 2-3.16A STANDARD CLASS**

Temperature, °F	Working Pressures by Classes, psig							
	150	300	400	600	900	1500	2500	4500
-20 to 100	275	720	960	1,440	2,160	3,600	6,000	10,800
200	245	635	850	1,270	1,910	3,180	5,300	9,540
300	225	590	785	1,175	1,765	2,940	4,900	8,820
400	200	550	735	1,105	1,655	2,760	4,600	8,280
500	170	525	700	1,050	1,575	2,630	4,380	7,885
600	140	500	670	1,005	1,505	2,510	4,180	7,525
650	125	490	655	980	1,470	2,450	4,080	7,345
700	110	480	645	965	1,445	2,410	4,020	7,235
750	95	470	625	940	1,410	2,350	3,920	7,055
800	80	465	620	925	1,390	2,315	3,860	6,950
850	65	455	605	905	1,360	2,270	3,780	6,805
900	50	445	590	885	1,330	2,215	3,690	6,640
950	35	385	515	775	1,160	1,930	3,220	5,795
1000	20	365	485	725	1,090	1,820	3,030	5,450
1050	20(1)	310	410	615	925	1,545	2,570	4,630
1100	20(1)	240	320	480	720	1,205	2,005	3,610
1150	20(1)	185	245	370	555	925	1,545	2,775
1200	20(1)	145	195	290	435	725	1,210	2,175
1250	20(1)	115	155	235	350	585	975	1,760
1300	20(1)	95	130	190	285	480	795	1,435
1350	20(1)	75	100	150	220	370	615	1,110
1400	20(1)	55	75	110	165	280	465	835
1450	20(1)	45	60	95	140	230	385	695
1500	15(1)	35	45	70	100	170	285	510

**NOTE:**

- (1) For welding end valves only. Flanged end ratings terminate at 1000°F.

**TABLE 2-3.16 (CONT'D)  
RATINGS FOR GROUP 3.16 MATERIALS**

B 511 Gr. N08330 (1)(2) B 535 Gr. N08330 (1) B 536 Gr. N08330 (1)

**NOTES:**

- (1) Use solution annealed material only.
- (2) For forgings, the chemical composition, mechanical properties, heat treating requirements, and grain size requirements shall conform to the applicable ASTM specification. The manufacturing procedures, tolerances, tests, certification, and markings shall be in accordance with ASTM B 564.

**TABLE 2-3.16B SPECIAL CLASS**

Temperature, °F	Working Pressures by Classes, psig							
	150	300	400	600	900	1500	2500	4500
-20 to 100	290	750	1,000	1,500	2,250	3,750	6,250	11,250
200	270	710	945	1,420	2,130	3,550	5,915	10,645
300	250	655	875	1,315	1,970	3,280	5,470	9,845
400	235	615	820	1,230	1,850	3,080	5,135	9,240
500	225	585	780	1,175	1,760	2,935	4,890	8,800
600	215	560	745	1,120	1,680	2,800	4,665	8,395
650	210	545	730	1,095	1,640	2,730	4,555	8,195
700	205	540	720	1,075	1,615	2,690	4,485	8,075
750	200	525	700	1,050	1,575	2,625	4,375	7,875
800	200	515	690	1,035	1,550	2,585	4,310	7,755
850	195	505	675	1,015	1,520	2,530	4,220	7,595
900	190	495	660	990	1,485	2,470	4,120	7,415
950	180	470	630	945	1,415	2,360	3,930	7,070
1000	160	420	560	840	1,260	2,105	3,505	6,310
1050	155	400	535	805	1,205	2,010	3,350	6,025
1100	120	315	420	625	940	1,565	2,610	4,700
1150	90	240	320	480	725	1,205	2,010	3,615
1200	70	190	250	380	565	945	1,575	2,835
1250	60	155	205	305	460	765	1,270	2,290
1300	50	125	165	250	375	625	1,040	1,870
1350	35	95	130	195	290	480	805	1,445
1400	30	70	95	145	215	360	605	1,085
1450	25	60	80	120	180	300	500	905
1500	15	45	60	90	135	220	370	665

VALVES — FLANGED,  
THREADED, AND WELDING END

ASME B16.34a-1998

**TABLE 2-3.17**  
**RATINGS FOR GROUP 3.17 MATERIALS**

(a)

A 351 Gr. CN7M (1)

NOTE:

(1) Use solution annealed material only.

**TABLE 2-3.17A STANDARD CLASS**

(a)

Temperature, °F	Working Pressures by Classes, psig							
	150	300	400	600	900	1500	2500	4500
-20 to 100	230	600	800	1,200	1,800	3,000	5,000	9,000
200	200	520	690	1,035	1,555	2,590	4,320	7,775
300	180	465	620	930	1,395	2,330	3,880	6,985
400	160	420	565	845	1,265	2,110	3,520	6,335
500	150	390	520	780	1,165	1,945	3,240	5,830
600	140	360	480	720	1,080	1,800	3,000	5,400

**TABLE 2-3.17B SPECIAL CLASS**

(a)

Temperature, °F	Working Pressures by Classes, psig							
	150	300	400	600	900	1500	2500	4500
-20 to 100	255	665	885	1,330	1,995	3,320	5,535	9,965
200	215	560	750	1,125	1,685	2,805	4,680	8,420
300	195	510	680	1,020	1,530	2,550	4,250	7,650
400	180	470	630	945	1,415	2,355	3,930	7,070
500	165	435	580	870	1,300	2,170	3,615	6,510
600	155	400	535	805	1,205	2,010	3,350	6,025

VALVES — FLANGED  
THREADED, AND WELDING END

ASME B16.34-1996

**TABLE 3 VALVE BODY MINIMUM WALL THICKNESS  $t_m$ , in.**

Inside Diameter $d$ , in. [Note (1)]	Class							
	150	300	400	600	900	1500	2500	4500
0.12	0.10	0.10	0.11	0.11	0.11	0.12	0.14	0.20
0.25	0.10	0.11	0.11	0.12	0.13	0.15	0.19	0.30
0.37	0.11	0.11	0.12	0.13	0.14	0.17	0.23	0.40
0.44	0.11	0.11	0.12	0.13	0.15	0.18	0.25	0.44
0.50	0.11	0.12	0.12	0.13	0.16	0.19	0.27	0.50
0.56	0.11	0.12	0.12	0.14	0.16	0.20	0.29	0.54
0.62	0.11	0.12	0.13	0.14	0.17	0.22	0.31	0.59
0.69	0.11	0.13	0.14	0.15	0.18	0.23	0.33	0.64
0.75	0.12	0.15	0.16	0.16	0.20	0.24	0.35	0.69
0.87	0.15	0.17	0.18	0.18	0.22	0.26	0.39	0.79
1.00	0.16	0.19	0.19	0.19	0.25	0.28	0.44	0.88
1.12	0.17	0.19	0.19	0.19	0.25	0.31	0.50	0.98
1.25	0.19	0.19	0.19	0.19	0.26	0.34	0.53	1.08
1.37	0.19	0.19	0.20	0.20	0.28	0.38	0.57	1.18
1.50	0.19	0.19	0.22	0.22	0.29	0.39	0.62	1.28
1.87	0.21	0.22	0.23	0.24	0.31	0.44	0.75	1.57
2.00	0.22	0.25	0.25	0.25	0.31	0.46	0.79	1.67
2.25	0.22	0.25	0.26	0.26	0.34	0.50	0.88	1.87
2.50	0.22	0.25	0.28	0.28	0.36	0.56	0.95	2.06
2.75	0.22	0.27	0.29	0.29	0.39	0.62	1.04	2.26
2.87	0.22	0.27	0.30	0.30	0.41	0.63	1.09	2.36
3.00	0.22	0.28	0.31	0.31	0.42	0.66	1.14	2.45
3.50	0.25	0.29	0.34	0.34	0.47	0.75	1.29	2.85
3.62	0.25	0.29	0.35	0.36	0.48	0.75	1.34	2.95
3.87	0.25	0.30	0.36	0.37	0.50	0.81	1.42	3.14
4.00	0.25	0.31	0.38	0.38	0.51	0.83	1.47	3.24
4.37	0.25	0.32	0.39	0.41	0.56	0.91	1.59	3.53
4.75	0.26	0.34	0.42	0.43	0.59	0.98	1.72	3.83
5.00	0.28	0.34	0.44	0.44	0.63	1.02	1.81	4.02
5.37	0.28	0.36	0.44	0.46	0.66	1.09	1.93	4.31
5.75	0.28	0.37	0.44	0.49	0.72	1.16	2.06	4.61
6.00	0.28	0.38	0.44	0.50	0.74	1.21	2.15	4.81
7.00	0.30	0.41	0.50	0.57	0.83	1.41	2.51	5.59
7.25	0.30	0.42	0.51	0.59	0.86	1.44	2.59	5.79
7.50	0.30	0.43	0.53	0.61	0.88	1.48	2.66	5.99
7.87	0.31	0.44	0.55	0.62	0.92	1.55	2.78	6.28
8.00	0.31	0.44	0.56	0.63	0.93	1.59	2.83	6.38
8.62	0.32	0.46	0.60	0.68	1.00	1.69	3.03	6.87
8.75	0.32	0.47	0.61	0.69	1.01	1.72	3.08	6.97
9.00	0.33	0.47	0.63	0.70	1.03	1.76	3.17	7.16
9.37	0.33	0.48	0.65	0.74	1.06	1.83	3.29	7.45
9.50	0.33	0.48	0.65	0.74	1.09	1.85	3.34	7.56
9.75	0.34	0.49	0.67	0.75	1.12	1.90	3.42	7.75
10.00	0.34	0.50	0.69	0.77	1.13	1.94	3.51	7.95
10.37	0.35	0.51	0.70	0.80	1.18	2.00	3.64	8.24

(Table 3 continues on next page)

(Note follows at end of table)



**TABLE 3 VALVE BODY MINIMUM WALL THICKNESS  $t_m$ , in. (CONT'D)**

Inside Diameter $d$ , in. [Note (1)]	Class							
	150	300	400	600	900	1500	2500	4500
10.87	0.36	0.53	0.71	0.84	1.24	2.10	3.81	8.64
11.00	0.36	0.53	0.72	0.85	1.24	2.12	3.85	8.73
11.12	0.36	0.54	0.72	0.85	1.25	2.15	3.89	8.83
11.37	0.37	0.55	0.73	0.87	1.29	2.19	3.98	9.02
11.75	0.37	0.56	0.75	0.91	1.33	2.27	4.11	9.32
12.00	0.38	0.56	0.75	0.92	1.35	2.31	4.19	9.52
12.25	0.38	0.57	0.76	0.93	1.38	2.36	4.27	9.71
12.87	0.39	0.59	0.79	0.97	1.44	2.47	4.49	10.21
13.00	0.40	0.61	0.81	0.97	1.46	2.50	4.52	10.30
13.12	0.40	0.61	0.81	0.99	1.47	2.52	4.57	10.40
13.25	0.41	0.62	0.81	1.00	1.48	2.54	4.62	10.50
13.50	0.41	0.63	0.82	1.01	1.51	2.59	4.69	10.70
14.00	0.42	0.65	0.84	1.03	1.56	2.69	4.86	11.09
14.62	0.43	0.66	0.86	1.09	1.63	2.81	5.08	11.58
14.75	0.43	0.67	0.87	1.09	1.64	2.82	5.13	11.68
14.87	0.43	0.67	0.88	1.11	1.65	2.84	5.16	11.78
15.00	0.43	0.68	0.88	1.11	1.67	2.88	5.20	11.87
15.25	0.44	0.69	0.89	1.13	1.69	2.91	5.30	12.07
15.75	0.45	0.70	0.90	1.17	1.75	3.00	5.47	12.46
16.00	0.45	0.71	0.91	1.18	1.77	3.06	5.54	12.66
16.37	0.46	0.72	0.93	1.21	1.81	3.12	5.68	12.95
16.50	0.46	0.73	0.93	1.22	1.82	3.14	5.72	13.05
17.00	0.46	0.75	0.94	1.25	1.86	3.24	5.90	13.44
17.25	0.47	0.75	0.97	1.27	1.90	3.28	5.98	13.64
17.50	0.47	0.76	0.98	1.29	1.91	3.33	6.07	13.84
17.62	0.48	0.76	0.98	1.29	1.94	3.35	6.11	13.93
18.00	0.48	0.78	1.00	1.31	1.96	3.42	6.24	14.23
18.25	0.49	0.78	1.02	1.34	2.01	3.47	6.32	14.42
18.87	0.50	0.80	1.06	1.38	2.07	3.58	6.53	14.91
19.00	0.50	0.81	1.07	1.39	2.07	3.61	6.58	15.01
19.25	0.50	0.82	1.07	1.40	2.10	3.65	6.66	15.21
19.62	0.51	0.83	1.09	1.43	2.15	3.72	6.79	15.50
20.00	0.51	0.84	1.10	1.46	2.17	3.79	6.92	15.80
20.12	0.51	0.84	1.10	1.47	2.20	3.81	6.96	15.89
20.37	0.51	0.85	1.11	1.48	2.23	3.86	7.05	16.09
20.75	0.52	0.86	1.12	1.51	2.27	3.93	7.17	16.39
21.00	0.53	0.88	1.13	1.53	2.28	3.97	7.26	16.58
21.25	0.53	0.88	1.14	1.54	2.32	4.02	7.34	16.78
22.00	0.54	0.91	1.17	1.59	2.40	4.15	7.60	17.37
22.62	0.55	0.93	1.19	1.63	2.46	4.27	7.81	17.85
22.75	0.55	0.93	1.20	1.64	2.48	4.30	7.86	17.96
23.00	0.56	0.94	1.20	1.66	2.50	4.33	7.94	18.15
23.25	0.57	0.95	1.21	1.68	2.53	4.39	8.03	18.35
23.75	0.58	0.96	1.23	1.70	2.58	4.48	8.20	18.74

VALVES — FLANGED,  
THREADED, AND WELDING END

ASME B16.34a-1998

**TABLE 3 VALVE BODY MINIMUM WALL THICKNESS  $t_m$ , in. (CONT'D)**

Inside Diameter $d$ , in. [Note (1)]	Class							
	150	300	400	600	900	1500	2500	4500
24.00	0.58	0.97	1.24	1.72	2.61	4.53	8.28	18.94
24.25	0.58	0.98	1.26	1.74	2.64	4.57	8.37	19.13
24.62	0.59	0.99	1.27	1.77	2.67	4.64	8.49	19.43
25.00	0.59	1.00	1.28	1.79	2.71	4.71	8.62	19.97
25.25	0.60	1.01	1.29	1.81	2.74	4.76	8.71	19.92
25.50	0.61	1.02	1.30	1.82	2.76	4.80	8.79	20.11
26.00	0.61	1.04	1.32	1.85	2.82	4.90	8.96	20.51
26.25	0.62	1.05	1.33	1.88	2.84	4.94	9.05	20.70
26.37	0.62	1.05	1.34	1.89	2.86	4.96	9.09	20.80
27.00	0.62	1.07	1.36	1.93	2.92	5.08	9.30	21.29
27.25	0.62	1.08	1.37	1.95	2.95	5.13	9.39	21.49
27.37	0.63	1.08	1.37	1.96	2.96	5.15	9.43	21.59
28.00	0.64	1.10	1.39	2.00	3.03	5.26	9.65	22.08
28.25	0.65	1.11	1.40	2.01	3.05	5.31	9.73	22.27
29.00	0.66	1.14	1.43	2.07	3.13	5.45	9.99	22.86
29.25	0.66	1.14	1.44	2.08	3.16	5.49	10.07	23.06
30.00	0.67	1.17	1.47	2.13	3.23	5.63	10.33	23.65
31.00	0.69	1.20	1.51	2.20	3.34	5.82	10.67	24.43
32.00	0.71	1.23	1.54	2.27	3.44	6.00	11.01	25.22
33.00	0.72	1.27	1.58	2.34	3.55	6.19	11.35	26.00
34.00	0.74	1.30	1.62	2.40	3.65	6.37	11.69	26.79
35.00	0.75	1.33	1.65	2.47	3.76	6.55	12.03	27.57
36.00	0.77	1.37	1.69	2.54	3.86	6.74	12.37	28.36
37.00	0.79	1.40	1.73	2.61	3.97	6.92	12.71	29.14
38.00	0.80	1.43	1.79	2.68	4.07	7.11	13.05	29.93
39.00	0.82	1.47	1.83	2.74	4.18	7.29	13.40	30.71
40.00	0.84	1.50	1.88	2.81	4.28	7.48	13.74	31.50
41.00	0.85	1.53	1.92	2.88	4.38	7.66	14.08	32.28
42.00	0.87	1.56	1.96	2.95	4.49	7.85	14.42	33.07
43.00	0.88	1.60	2.01	3.01	4.59	8.03	14.76	33.85
44.00	0.90	1.63	2.05	3.08	4.70	8.21	15.10	34.63
45.00	0.92	1.66	2.10	3.15	4.80	8.40	15.44	35.42
46.00	0.93	1.70	2.14	3.22	4.91	8.58	15.78	36.20
47.00	0.95	1.73	2.19	3.29	5.01	8.77	16.12	36.99
48.00	0.97	1.76	2.23	3.35	5.12	8.95	16.46	37.77
49.00	0.98	1.80	2.27	3.42	5.22	9.14	16.80	38.56
50.00	1.00	1.83	2.32	3.49	5.32	9.32	17.15	39.34

NOTE:

(1) See para. 6.1.2.

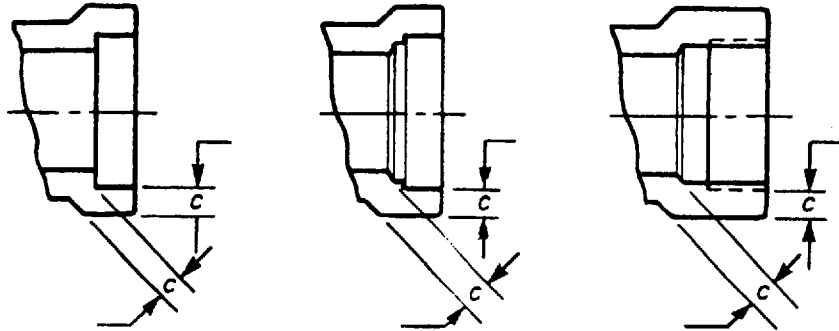

(a) **TABLE 4 MINIMUM WALL THICKNESS FOR SOCKET WELDING AND THREADED ENDS**

Size NPS	Wall Thickness C, in.						
	Pressure Rating Class Designation						
	150 Through 300	400 Through 600	800 [Note (1)]	900	1500	2500	4500
1/8	0.12	0.12	0.12	0.14	0.14	0.21	0.22
1/4	0.12	0.13	0.13	0.16	0.16	0.26	0.29
3/8	0.12	0.14	0.14	0.17	0.17	0.28	0.37
1/2	0.13	0.16	0.16	0.21	0.21	0.32	0.44
3/4	0.14	0.17	0.17	0.24	0.24	0.34	0.51
1	0.15	0.20	0.20	0.27	0.27	0.39	0.62
1 1/4	0.15	0.21	0.21	0.28	0.32	0.46	0.75
1 1/2	0.16	0.22	0.23	0.31	0.35	0.51	0.84
2	0.18	0.24	0.27	0.38	0.42	0.62	1.02
2 1/2	0.22	0.30	0.31	0.41	0.49	0.73	1.22

**NOTE:**

(1) Class 800 is not a normally tabulated ASME B16.34 designation, but it is an intermediate class that is widely used for socket welding and threaded end valves.

**ANNEX A**

(a)

**RELATIONSHIP BETWEEN NOMINAL PIPE SIZE AND INSIDE DIAMETER**

(This Annex is a nonmandatory part of ASME B16.34-1996 and is provided for information purposes only.)

The relationship between wall thickness and inside diameter shown in Table 3 is the basis for pressure rating of valves. By interpolation, a definitive design basis can be determined for any pressure-diameter-material combination.

Following the evolution of standard dimensions for flanges in a series of rating classes, corresponding standard relationships were established between nominal pipe sizes and the inside diameter of fittings matching the rating class of the flanges. These provided a useful

design basis for the corresponding flanged end valves, subsequently extended in application to welding end valves, which in many cases are identical except for the pipe ends. Table A1 is based on the dimensions given in B16.5 dimensional tables as "Inside Diameter of Fitting." The values above nominal pipe size 24 for the lower pressure classes and above nominal pipe size 12 for Class 2500 are obtained by linear extrapolation.

**TABLE A1 INSIDE DIAMETER *d*, in.**

Nominal Pipe Size	Class						
	150	300	400	600	900	1500	2500
1/2	0.50	0.50	0.50	0.50	0.50	0.50	0.44
3/4	0.75	0.75	0.75	0.75	0.69	0.69	0.56
1	1.00	1.00	1.00	1.00	0.87	0.87	0.75
1 1/4	1.25	1.25	1.25	1.25	1.12	1.12	1.00
1 1/2	1.50	1.50	1.50	1.50	1.37	1.37	1.12
2	2.00	2.00	2.00	2.00	1.87	1.87	1.50
2 1/2	2.50	2.50	2.50	2.50	2.25	2.25	1.87
3	3.00	3.00	3.00	3.00	2.87	2.75	2.25
4	4.00	4.00	4.00	4.00	3.87	3.62	2.87
5	5.00	5.00	5.00	5.00	4.75	4.37	3.62
6	6.00	6.00	6.00	6.00	5.75	5.37	4.37
8	8.00	8.00	8.00	7.87	7.50	7.00	5.75
10	10.00	10.00	10.00	9.75	9.37	8.75	7.25
12	12.00	12.00	12.00	11.75	11.12	10.37	8.62
14	13.25	13.25	13.12	12.87	12.25	11.37	9.50
16	15.25	15.25	15.00	14.75	14.00	13.00	10.87
18	17.25	17.00	17.00	16.50	15.75	14.62	12.25
20	19.25	19.00	18.87	18.25	17.50	16.37	13.50
22	21.25	21.00	20.75	20.12	19.25	18.00	14.87
24	23.25	23.00	22.62	22.00	21.00	19.62	16.25
26	25.25	25.00	24.50	23.75	22.75	21.25	17.62
28	27.25	27.00	26.37	25.50	24.50	23.00	19.00
30	29.25	29.00	28.25	27.37	26.25	24.62	20.37

**ANNEX B**  
**RADIOGRAPHY PROCEDURE AND ACCEPTANCE STANDARDS**

(This Annex is an integral part of ASME B16.34-1996 and is placed after the main text for convenience.)

**B1 RADIOGRAPHY PROCEDURE**

**B1.1** ASTM E 94, Recommended Practice for Radiographic Testing, and ASTM E 142, Controlling Quality of Radiographic Testing, shall be used as a guide.

**B1.2** The film shall be as close as practical to the part being radiographed.

**B1.3** Any commercially available intensifying screen, except those of the fluorescent type, may be used.

**B1.4** All film shall bear identification markers to properly orient the film for interpretation and to denote the actual part under examination. Film shall be marked to identify the organization producing the radiograph and the date exposed.

**B1.5** Penetrators shall be used on each radiograph. Penetrators shall conform to the requirements of ASTM E 142.

**B1.6** Any commercially available film may be used, provided it is equal to or finer grained than Type 2, ASTM E 94.

**B1.7** The manufacturer, at his option, may use a double film technique and a combination of a single and double viewing so as to cover a greater latitude in part thickness with a single exposure.

**B1.8** Radiographs shall be within the following photographic (H & D) density range:

(a) single film viewing — 1.5 minimum, 4.0 maximum;

(b) superimposed viewing of double film, each single film — 1.00 minimum, 2.5 maximum, with a double film — 4.0 maximum.

**B1.9** Surfaces shall be such that radiographic contrast due to surface condition cannot mask or be confused with that of any defect.

**B1.10** Single wall thickness shall be radiographed wherever practical.

**B1.11** The radiographic sensitivity shall be 2-4T for thickness up to and including 0.75 in. and 2-2T for thickness 1 greater than 0.75 in.

**B2 ACCEPTANCE STANDARDS**

**B2.1** Acceptance shall be based on the following.

**B2.1.1 Wall Thickness Less Than 2 in.** The following comparative plates of ASTM E 446 define acceptable indications as follows.

Discontinuity Type	Category	Acceptable Comparative Plate, ASTM E 446
Gas	A	A2
Sand	B	B3
Shrink, Type 1	C	CA2
Shrink, Type 2	C	CB3
Shrink, Type 3	C	CC3
Shrink, Type 4	C	CD3
Hot tears and cracks	D & E	None
Inserts (chills, chaplets)	F	None

**B2.1.2 Wall Thickness 2 in. to 4.5 in.** The following comparative plates of ASTM E 186 define acceptable indications as follows.

Discontinuity Type	Category	Acceptable Comparative Plate, ASTM E 186
Gas porosity	A	A3
Sand and slag inclusions	B	B3
Shrink, Type 1	C	CA3
Shrink, Type 2	C	CB3
Shrink, Type 3	C	CC3
Crack	D	None
Hot tear	E	None
Insert	F	None

**B2.1.3 Wall Thickness 4.5 in. to 12 in.** The following comparative plates of ASTM E 280 define acceptable indications as follows.

Discontinuity Type	Category	Acceptable Comparative Plate, ASTM E 280
Gas porosity	A	A3
Sand and slag inclusions	B	B3
Shrink, Type 1	C	CA3
Shrink, Type 2	C	CB3
Shrink, Type 3	C	CC3
Crack	D	None
Hot tear	E	None
Insert	F	None

**ANNEX C****MAGNETIC PARTICLE EXAMINATION PROCEDURE AND ACCEPTANCE STANDARDS**

(This Annex is an integral part of ASME B16.34-1996 and is placed after the main text for convenience.)

**C1 PROCEDURE**

Magnetic particle examination procedure for castings shall be in accordance with ASTM E 709, Standard Recommended Practice for Magnetic Particle Examination. For forgings and bars, the examination procedures shall be in accordance with ASTM A 275, Magnetic Particle Examination of Steel Forgings.

**C2 ACCEPTANCE STANDARDS****C2.1 Castings**

Maximum acceptable indications are as follows:

*(a) Linear Indications:*

- (1) 0.3 in. long for materials up to 0.5 in. thick;
- (2) 0.5 in. long for materials 0.5 in. to 1 in. thick;
- (3) 0.7 in. long for materials over 1 in. thick

For linear indications, the indications must be separated by a distance greater than the length of an acceptable indication. A linear indication is one with length in excess of 3 times the width.

*(b) rounded Indications:*

- (1) 0.3 in. diameter for materials up to 0.5 in. thick;
- (2) 0.5 in. diameter for materials over 0.5 in. thick

Four or more rounded indications in a line separated by 0.06 in. or less edge to edge are unacceptable. Rounded indications are those which are not defined as linear indications.

**C2.2 Forgings and Rolled or Wrought Material**

Maximum acceptable indications are as follows:

*(a) Linear Indications:*

- (1) 0.2 in long for materials up to 0.5 in. or less thick;
- (2) 0.4 in long for materials over 0.5 in. to 1 in. thick;
- (3) 0.6 in. long for materials over 1 in. thick.

For linear indications, the indications must be separated by a distance greater than the length of an acceptable indication. A linear indication is one with length in excess of 3 times the width.

*(b) Rounded Indications*

- (1) 0.2 in. diameter for materials up to 0.5 in. thick;
- (2) 0.3 in. diameter for materials over 0.5 in. thick.

Four or more rounded indications in a line separated by a 0.06 in. or less edge to edge are unacceptable. Rounded indications are those which are not defined as linear indications.

## ANNEX D

### LIQUID PENETRANT EXAMINATION PROCEDURE AND ACCEPTANCE STANDARDS

(This Annex is an integral part of ASME B16.34-1996 and is placed after the main text for convenience.)

#### D1 PROCEDURE

Liquid penetrant procedure shall be in accordance with ASTM E 165.

#### D2 ACCEPTANCE STANDARDS

##### D2.1 Castings

Maximum acceptable indications are as follows:

*(a) Linear Indications:*

- (1) 0.3 in. Long for materials up to 0.5 in. thick;
- (2) 0.5 in. Long for materials 0.5 in. to 1 in. thick;
- (3) 0.7 in. Long for materials over 1 in. thick.

For linear indications, the indications must be separated by a distance greater than the length of an acceptable indication. A linear indication is one with length in excess of 3 times the width.

*(b) Rounded Indications:*

- (1) 0.3 in. diameter for materials up to 0.5 in. thick;
- (2) 0.5 in. diameter for materials over 0.5 in. thick.

Four or more rounded indications in a line separated by 0.06 in. or less edge to edge are unacceptable.

Rounded indications are those which are not defined as linear indications.

##### D2.2 Forgings and Rolled or Wrought Material

Maximum acceptable indications are as follows:

*(a) Linear Indications:*

- (1) 0.2 in. long for materials 0.5 in. or less thick;
- (2) 0.4 in. long for materials over 0.5 in. to 1 in. thick;
- (3) 0.6 in. long for materials over 1 in. thick.

For linear indications, the indications must be separated by a distance greater than the length of an acceptable indication. A linear indication is one with length in excess of 3 times the width.

*(b) Rounded Indications:*

- (1) 0.2 in. diameter for materials up to 0.5 in. thick;
- (2) 0.3 in. diameter for materials over 0.5 in. thick.

Four or more rounded indications in a line separated by 0.06 in. or less edge to edge are unacceptable. Rounded indications are those which are not defined as linear indications.



## ANNEX E

### ULTRASONIC EXAMINATION PROCEDURE AND ACCEPTANCE STANDARDS

(This Annex is an integral part of ASME B16.34-1996 and is placed after the main text for convenience.)

#### E1 PROCEDURE

Ultrasonic examination procedure shall meet the requirements of ASTM A 388 for forgings, bars, plates, and tubular products and ASTM A 609 for castings.

#### E2 ACCEPTANCE STANDARDS

##### E2.1 Straight Beam Examination

Indications which are equal to or exceed that obtained from a 0.25 in. diameter flat bottomed hole in a calibration test piece of thickness equal to the defect depth are unacceptable.

##### E2.2 Angle Beam Examination

Indications which are equal to or exceed those obtained from a 60 deg. V-notch 1 in. long and having a depth not greater than 5% of the nominal wall thickness in a test piece are unacceptable.

## ANNEX F

### METHODS FOR ESTABLISHING PRESSURE-TEMPERATURE RATINGS

(This Annex is an integral part of ASME B16.34-1996 and is placed after the main text for convenience.)

#### F1 GENERAL CONSIDERATIONS

##### F1.1 Introduction

Pressure-temperature ratings for this Standard have been determined by the procedures described in this Annex. The method is general and considers dimensions of this and related standards. Valve performance is related to stress and deformation. Valves require special consideration since they are mechanically operated devices that must be able to provide partial or complete restriction to fluid flow under a wide variety of conditions.

##### F1.2 Materials

It is not required that identical materials be used for a valve body and bonnet or a valve body and cover. The assigned pressure rating shall be based on the valve body. The bonnet or cover shall be designed and the material selected accordingly. Selection of stems, discs, and other parts, such as bonnet gaskets and bolting, subject to pressure and other loading, shall be consistent with the pressure-temperature rating.

##### F1.3 Wall Thickness

Wall thickness requirements for valve bodies are specified in para. 6.1. The minimum wall thickness values shown in Table 3 are all greater than those determined by the following equation.

$$t = 1.5 \left[ \frac{P_c d}{2S - 1.2P_c} \right]$$

where

- $t$  = calculated thickness, in.
- $P_c$  = pressure rating class designation or number, psi (e.g., for Class 150,  $P_c = 150$  psi; for Class 300,  $P_c = 300$  psi)
- $d$  = inside diameter or port opening as defined in para. 6.1.2, in. (see Table 3 and Annex A)
- $S$  = stress factor of 7,000 psi

The equation does not apply for values of  $P_c$  greater than 4,500.

##### F1.4 Additional Considerations

The equation in para. F1.3 results in a wall thickness of 50% greater for Class 150 to 2500 and approximately 35% greater for Class 4500 than for a simple cylinder designed for a stress of 7000 psi subjected to an internal pressure equal to the pressure rating class designation. The actual values in Table 3 are approximately 0.1 in. heavier than those given by the equation. Additional metal thickness, particularly for ratings over Class 2500, needed for assembly stress, valve closing stresses, shapes other than circular, and stress concentrations must be determined by individual manufacturers, since these factors vary widely.

##### F1.5 Material Properties

The pressure-temperature rating method uses allowable stresses and yield strengths from reference ASME Boiler and Pressure Vessel Code Sections. For materials listed herein which have temperature tabulations above those listed or are not listed at all, allowable stresses and yield strength data have been provided directly by the ASME Boiler and Pressure Vessel Subcommittee on Materials.

##### F1.6 Material Groups

Materials are grouped in Table 1 based on identical or closely matched allowable stress and yield strength values. When these values are not identical for each material listed, the lowest value has been used.

#### F2 STANDARD CLASS RATING METHOD

##### F2.1 Method for Group 1 Materials (a)

Pressure-temperature ratings for Standard Class valves, Class 300 and higher, of materials corresponding to those in Materials Group 1 of Table 1, are established by the equation

$$p_{st} = \frac{S_1}{8750} P_r \leq p_{ca}$$

where

$p_{st}$  = rated working pressure, psi for the specified material at temperature  $T$

$p_{ca}$  = ceiling pressure, psi, at temperature  $T$  as specified in Section F4 for Standard Class

$P_r$  = pressure rating class index, psi. For all designations Class 300 and above,  $P_r$  equal to the class designation (e.g., for Class 300,  $P_r = 300$  psi; for Class 150, see para. F2.3 of this Annex)

$S_1$  = selected stress, psi, for the specified material at temperature  $T$ . The value of  $S_1$  shall be established as follows.

(a) At temperatures below the creep range,  $S_1$  shall be equal to or less than 60% of the yield strength at temperature  $T$ , but shall not exceed:

(1) 60.0% of the specified minimum yield strength at 100°F:

(2) 1.25 times the allowable stress value at temperature  $T$ , as listed in ASME Boiler and Pressure Vessel Code, Section II, Part D, for either Section I or Section VIII, Division 1;

(b) At temperatures in the creep range, the value of  $S_1$  shall be the allowable stress at temperature  $T$ , as listed in ASME Boiler and Pressure Vessel Code, Section II, Part D, for either Section I or Section VIII, Division 1, but not exceeding 60% of the yield strength at temperature.

(c) In no case shall the selected stress value increase with increasing temperature.

(a) (d) The creep range is considered to be at temperatures in excess of 700°F for Group 1 materials and 950°F for Group 2 materials, unless material properties indicate lower temperatures to be used. For Group 3 materials, the creep range temperature limits shall be determined on an individual material basis.

(e) When the allowable stresses listed for the referenced ASME Boiler and Pressure Vessel Code Section show a higher and lower value for allowable stress and the higher value is noted to the effect that these stress values exceed two-thirds of the yield strength at temperature, then the lower value shall be used. If lower allowable stress values do not appear and it is noted in the allowable stress table that the allowable stress values exceed two-thirds of the yield strength at temperature, then the allowable stress values shall be determined as two-thirds of the tabulated yield strength at temperature.

(f) Yield strength shall be as listed in ASME Boiler and Pressure Vessel Code, Section II, Part D, for either Section III or Section VIII, Division 2.

(g) Allowable stress values as listed in ASME Boiler and Pressure Vessel Code, Section II, Part D, for Section III, Class 2 or Class 3 values only, may be used for a material not listed for either Section I or Section VIII, Division 1.

## F2.2 Method for Groups 2 and 3 Materials

Pressure-temperature ratings for Standard Class valves, Class 300 and higher, of materials corresponding to those in Materials Groups 2 and 3 of Table 1 are established by the method of para F2.1, except that in paras. F2.1(a) and F2.1(a)(1), 60% shall be changed to 70%.

## F2.3 Method for Class 150 — All Materials

Pressure-temperature ratings for Standard Class valves, Class 150 rating designation, are established by the method given for the related materials in paras. F2.1 and F2.2, subject to the following additional requirements:

$P_r = 115$  psi. For a rating designation less than Class 300, an interpolation must be made using  $P_r = 115$  psi for Class 150.

$S_1$  = selected stress, psi, for the specific material at temperature  $T$  in accordance with the requirements stated in either para. F2.1 or F2.2

$p_{st}$  = rated working pressure, psi, for temperatures 100°F and lower, shall not exceed values at temperature  $T$  expressed in degrees Fahrenheit, as given by the equation.

$$p_{st} = 320 - 0.3T$$

For values of temperature less than 100°F, use  $T$  equal to 100°F.

## F3 SPECIAL CLASS RATING METHOD

### F3.1

Pressure-temperature ratings for Special Class valves (see 2.1.2) are established for all materials of Table 1 by the equation

$$p_{sp} = \frac{S_2}{7000} P_r \leq p_{cb}$$

where

$p_{sp}$  = Special Class rated working pressure for the specified material at temperature  $T$ , psi

VALVES – FLANGED,  
THREADED, AND WELDING END

ASME B16.34a-1998

$P_{cb}$  = ceiling pressure, psi, at temperature  $T$  as specified in para. F4 for Special Class

$P_r$  = pressure rating class index, psi. For all designations Class 300 and above  $P_r$  is equal to the class designation (e.g. for Class 300,  $P_r = 300$  psi). For Class 150,  $P_r = 115$  psi. For a rating designation less than Class 300, an interpolation is required using  $P_r = 115$  psi for Class 150

$S_2$  = selected stress for the specified material at temperature  $T$ , psi. The value of  $S_2$  shall be established as follows.

(a) At temperatures below the creep range,  $S_2$  shall be equal to or less than 62.5% of the yield strength at temperature  $T$ , but shall not exceed:

(1) 62.5% of the specified minimum yield strength at 100°F;

(2) 1.0 times the allowable stress value at temperature  $T$ , as listed in ASME Boiler and Pressure Vessel Code, Section II, Part D, for either Section I or Section VIII, Division 1.

(b) At temperatures in the creep range, the value of  $S_2$  shall be the allowable stress at temperature  $T$ , as listed in ASME Boiler and Pressure Vessel Code, Section II, Part D, for either Section I or Section VIII, Division 1, but shall not exceed 62.5% of the yield strength at temperature  $T$ .

(c) In no case shall the selected stress value increase with increasing temperature.

(d) The creep range is to be considered that at temperatures in excess of 700°F for Group 1 materials and 950°F for Group 2 materials, unless material properties indicate lower temperatures to be used. For Group

3 materials, the creep range temperature limits shall be determined on an individual material basis.

(e) When the allowable stresses listed for the referenced ASME Boiler and Pressure Vessel Code Section show a higher and lower value for allowable stress and the higher value is noted to the effect that these stress values exceed two-thirds of the yield strength at temperature, then the lower value shall be used. If lower allowable stress values do not appear and it is noted in the allowable stress table that the allowable stress values exceed two-thirds of the yield strength at temperature, then the allowable stress values shall be determined as two-thirds of the tabulated yield strength at temperature.

(f) Yield strength shall be as listed in ASME Boiler and Pressure Vessel Code, Section II, Part D, for either Section III or Section VIII, Division 2.

(g) Allowable stress values as listed in ASME Boiler and Pressure Vessel Code, Section II, Part D, for Section III, Class 2 or Class 3 values only, may be used for a material not listed for either Section I or Section VIII, Division 1.

**F4 MAXIMUM RATINGS**

The rules for establishing Standard Class and Special Class pressure-temperature ratings include consideration of a ceiling pressure that effectively sets limits on the selected stress. The ceiling pressure-temperature values set an upper bound for high strength materials and are imposed to limit deflection. By definition, ceiling values apply to all intermediate ratings (para. 2.1.4). Ceiling values are listed in Tables F4-A and F4-B. Except for Limited Class, ratings in excess of these are not permitted under this Standard.

**TABLE F4  
PRESSURE RATING CEILING VALUES**

**(a) TABLE F4-A STANDARD CLASS VALVES**

Temperature, °F	Working Pressures by Classes, psig							
	150	300	400	600	900	1500	2500	4500
-20 to 100	290	750	1,000	1,500	2,250	3,750	6,250	11,250
200	260	750	1,000	1,500	2,250	3,750	6,250	11,250
300	230	730	970	1,455	2,185	3,640	6,070	10,925
400	200	705	940	1,410	2,115	3,530	5,880	10,585
500	170	665	885	1,330	1,995	3,325	5,540	9,965
600	140	605	805	1,210	1,815	3,025	5,040	9,070
650	125	590	785	1,175	1,765	2,940	4,905	8,825
700	110	570	755	1,135	1,705	2,840	4,730	8,515
750	95	530	710	1,065	1,595	2,660	4,430	7,970
800	80	510	675	1,015	1,525	2,540	4,230	7,610
850	65	485	650	975	1,460	2,435	4,060	7,305
900	50	450	600	900	1,350	2,245	3,745	6,740
950	35	385	515	775	1,160	1,930	3,220	5,795
1000	20	365	485	725	1,090	1,820	3,030	5,450
1050	20(1)	360	480	720	1,080	1,800	3,000	5,400
1100	20(1)	325	430	645	965	1,610	2,685	4,835
1150	20(1)	275	365	550	825	1,370	2,285	4,115
1200	20(1)	205	275	410	620	1,030	1,715	3,085
1250	20(1)	180	245	365	545	910	1,515	2,725
1300	20(1)	140	185	275	410	685	1,145	2,060
1350	20(1)	105	140	205	310	515	860	1,545
1400	20(1)	75	100	150	225	380	630	1,130
1450	20(1)	60	80	115	175	290	485	875
1500	15(1)	40	55	85	125	205	345	620

**NOTE:**

(1) For welding end valves only. Flanged end ratings terminate at 1000°F.

VALVES — FLANGED  
 THREADED, AND WELDING END

ASME B16.34-1996

**TABLE F4-B SPECIAL CLASS VALVES**

Temperature, °F	Working Pressures by Classes, psig							
	150	300	400	600	900	1500	2500	4500
-20 to 100	290	750	1,000	1,500	2,250	3,750	6,250	11,250
200	290	750	1,000	1,500	2,250	3,750	6,250	11,250
300	290	750	1,000	1,500	2,250	3,750	6,250	11,250
400	290	750	1,000	1,500	2,250	3,750	6,250	11,250
500	290	750	1,000	1,500	2,250	3,750	6,250	11,250
600	290	750	1,000	1,500	2,250	3,750	6,250	11,250
650	290	750	1,000	1,500	2,250	3,750	6,250	11,250
700	280	735	980	1,465	2,200	3,665	6,110	10,995
750	280	730	970	1,460	2,185	3,645	6,070	10,930
800	275	720	960	1,440	2,160	3,600	6,000	10,800
850	260	680	905	1,355	2,030	3,385	5,645	10,160
900	230	600	800	1,200	1,800	3,000	5,000	9,000
950	180	470	630	945	1,415	2,360	3,930	7,070
1000	160	420	560	840	1,260	2,105	3,505	6,310
1050	160	420	560	840	1,260	2,105	3,505	6,310
1100	155	405	540	805	1,210	2,015	3,360	6,045
1150	130	345	460	685	1,030	1,715	2,860	5,145
1200	100	260	345	515	770	1,285	2,145	3,860
1250	90	230	305	455	680	1,135	1,895	3,410
1300	65	170	230	345	515	860	1,430	2,570
1350	50	130	170	260	385	645	1,070	1,930
1400	35	95	125	190	285	470	785	1,415
1450	30	75	100	145	220	365	610	1,095
1500	20	50	70	105	155	260	430	770

## ANNEX G

### REQUIREMENTS FOR LIMITED CLASS VALVES

(This Annex is an integral part of ASME B16.34-1996 and is placed after the main text for convenience.)

#### G1.1 General

This Annex covers alternative requirements for valves having either threaded or welding ends and is specifically restricted to sizes NPS 2½ and smaller. Small valves complying with these requirements may be designated as Limited Class. There is no provision for this designation for flanged end valves.

#### G1.2 Applicability

The paragraphs of this Annex are numbered corresponding with those of the body of the Standard. All requirements for Standard Class valves are applicable to Limited Class except as otherwise modified by this Annex. Small valves are defined as sized NPS 2½ and smaller.

#### G2.1 General

Small valves conforming to the requirements of this Annex and identified as Limited Class shall be suitable for pressure-temperature ratings determined in accordance with para. G2.1.3. Threaded end valves rated above Class 2500 and socket-weld-end valves rated above Class 4500 are not within the scope of this Standard.

- (a) **G2.1.3 Limited Class Rating Method.** Pressure-temperature ratings for Limited Class valves are established for Group 1 and Group 2 materials of Table 1 by the equation

$$P_{ld} = \frac{7000}{7000 - (y - 0.4) P_r} P_{sp}$$

where

- $P_{ld}$  = Limited Class rated working pressure for the specified material at temperature  $T$ , psi
- $P_r$  = pressure rating class index, psi. For all designations Class 300 through 4500,  $P_r$  is equal to the class designation (e.g., for Class 300,  $P_r = 300$  psi). For Class 150,  $P_r = 115$  psi. For a rating designation less than Class 300,

an interpolation is required using  $P_r = 115$  psi for Class 150. The equation is not valid for  $P_r$  greater than 4500 psi.

$P_{sp}$  = Special Class rated working pressure for the specified material at temperature  $T$  as determined by the method of Section F3, psi. These Special Class working pressures are tabulated in Tables 2 having an identifying suffix "B." The tabulated values shall be used for establishing Limited Class ratings.

$y$  = a coefficient having values as follows:

	Temperature, °F					
	900 and Below	950	1000	1050	1100	1150 and Above
Ferritic Steels	0.4	0.5	0.7	0.7	0.7	0.7
Austenitic Steels	0.4	0.4	0.4	0.4	0.5	0.7
Other Ductile Materials	0.4	0.4	0.4	0.4	0.4	0.4

In no case shall the working pressure increase with increasing temperature. This shall be verified by the manufacturer for all rating points greater than 900°F for ferritic steels and 1050°F for austenitic steels.

- G2.1.5 Fabrication by Welding.** Fabricated valves that are identified as Limited Class shall conform with the requirements of para. 2.1.5(c)(2) for Special Class.

**G4.1.3 Rating.** Small valves shall be marked on the valve body with the number for the appropriate pressure rating class designation except that Limited Class and Intermediate Rating Limited Class may instead be marked on the valve body with a specific rated pressure and temperature. For all small valves in Limited Class, the identification plate shall show the applicable pressure rating at 100°F and other markings required by MSS SP-25. Valves conforming to Limited Class requirements shall include the designation "B16.34LTD" on the identification plate.

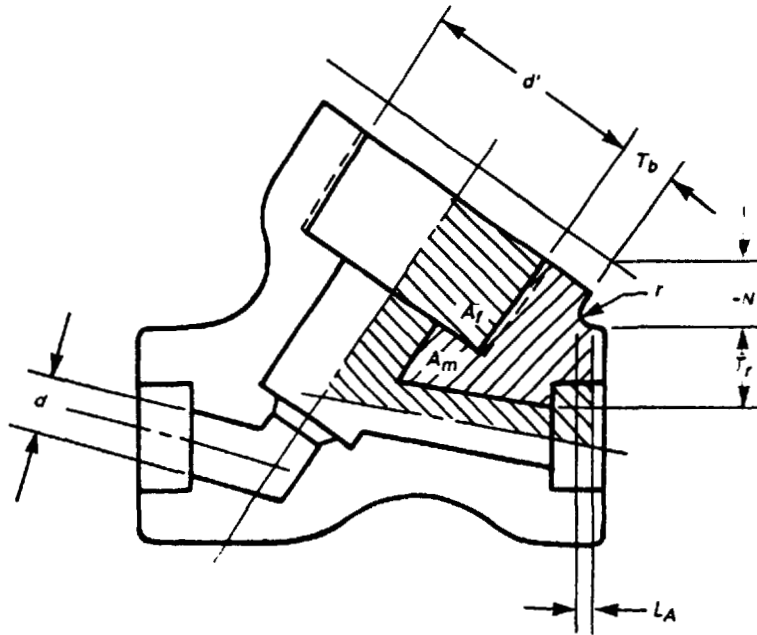

FIG. G1 LIMITED CLASS STRESS AREA LIMITS

**G6.1 Body Dimensions**

Limited Class is restricted in application to valve body geometries that have internal wetted pressure boundary surfaces that are generally characterized by cylindrical passages, cylindrical or spherical chambers, and intersections thereof.

**G6.1.1 Wall Thickness.** For inspection purposes, the minimum thickness of the wall surrounding the body run flow passage shall be as shown in Table 3.

**G6.1.2 Inside Diameter.** For the purpose of determining flow passageway wall thickness, the inside diameter  $d$  (see Fig. G1), is the diameter of the cylindrical flow passage.

**G6.1.3 Valve Body Necks.** The minimum thickness of the wall for the body neck shall be that shown in Table 3 with  $d$  for this determination taken as two-thirds of  $d'$  where  $d'$  is the inside diameter of the body neck. In no case shall the body neck thickness be less than the minimum value determined for the flow passage in para. G6.1.1. For values of body neck inside diameter not shown in Table 3, interpolation is permitted.

<sup>1</sup>For guidance in regard to other valve configurations, see ASME Boiler and Pressure Vessel Code, Section III, NB-3545.

**G6.1.5 Contours for Body Run Transitions.**

The requirements of para. 6.1.5 are not applicable to Limited Class.

**G6.1.8 Additional Metal Thickness.** For Limited Class, it is required that metal thickness reinforcement be provided to satisfy the following: (a)

$$S_o \geq p_o \left( \frac{A_f}{A_m} + 0.5 \right)$$

where

$S_o$  = allowable stress of the body material at 100°F from the ASME Boiler and Pressure Vessel Code, Section II, Part D, for either Section I or Section VIII, Div. 1;

$p_o$  = rated working pressure at 100°F

$A_f$  = fluid area (see Fig. G1)

$A_m$  = metal area (see Fig. G1)

The fluid area and metal area are determined from a drawing of the valve body crotch region in the mutual plane of the bonnet and flow passage center lines (see Fig. G1).<sup>1</sup> The fluid and metal areas are to be based on the most adverse combination of dimensions permitted by tolerances. In Fig. G1, the distances  $L_N$  and



VALVES — FLANGED  
THREADED, AND WELDING END

ASME B16.34-1996

$L_A$  which define fluid and metal area boundaries are determined as

$$L_N = 0.5r + 0.354 \sqrt{T_b (d' + T_b)}$$

and  $L_A$  as the larger of

$$L_A = 0.5d' - T_b$$

or

$$L_A = T_r$$

where

- $d'$  = body neck inside diameter at crotch region
- $T_b$  = neck wall thickness at crotch region
- $T_r$  = body run wall thickness at crotch region
- $r$  = external fillet radius at crotch

If a calculated boundary lies beyond the body run end or neck end, the sections to be used for area determination shall terminate at the body run end or neck end.

## ANNEX H

### QUALITY SYSTEM PROGRAM

(This is a nonmandatory part of ASME B16.34-1996 and is provided for information purposes only.)

The products manufactured in accordance with this standard shall be produced under quality system program following the principles of an appropriate standard from the ISO 9000 series.<sup>1</sup> A determination of the need for registration and/or certification of the products manufac-

turer's quality system program by an independent organization shall be the responsibility of the manufacturer. The detailed documentation demonstrating program compliance shall be available to the purchaser at the manufacturer's facility. A written summary description of the program utilized by the product manufacturer shall be available to the purchaser upon request. The product manufacturer is defined as the entity whose name or trademark appears on the product in accordance with the marking or identification requirements of this Standard.

---

<sup>1</sup> The series is also available from the American National Standards Institute (ANSI) and the American Society for Quality Control (ASQC) as American National Standards that are identified by a prefix "Q" replacing the prefix "ISO". Each standard of the series is listed under references.

## ANNEX I

### REFERENCE STANDARDS AND SPECIFICATIONS

(This Annex is an integral part of ASME B16.34-1996 and is placed after the main text for convenience.)

Standards and specifications referenced in this Standard are listed showing the year of approved issue. Products covered by each ASTM specification are listed for convenience. (See specifications for exact titles and detailed contents.)

Publications of the following organizations appear in this list.

ASME	The American Society of Mechanical Engineers Three Park Avenue, New York, New York 10016-5990	(a)
ASQC	American Society for Quality Control P.O. Box 3005, Milwaukee, Wisconsin 53201-3005	
ASTM	American Society for Testing and Materials 100 Barr Harbor Drive, West Conshohocken, Pennsylvania 19428-2959	
MSS	Manufacturer's Standardization Society for the Valves and Fittings Industry 127 Park Street NE, Vienna, Virginia 22180	
API	American Petroleum Institute 1220 L Street NW, Washington, D.C. 20005	
ISO	International Organization for Standardization 1, rue de Varembe, Case postale 56, CH - 1211 Geneve 20, Switzerland/Suisse	

ISO documents are also available from ANSI. Publications appearing below which have been approved as American National Standards may also be obtained from:

ANSI	American National Standards Institute 11 West 42nd Street, New York, New York 10036
------	--

#### ASME Publications

ASME B1.1-1989	Unified Inch Screw Threads (UN and UNR Thread Form)
ANSI B1.20.1-1983 (R1992)	Pipe Threads, General Purpose (Inch)
ASME B16.5-1996	Flanges and Flanged Fittings
ASME B16.10-1992	Face-to-Face and End-to-End Dimensions of Ferrous Valves
ASME B16.11-1991	Forged Steel Fittings, Socket-Welding and Threaded
ASME B16.20-1993	Ring-Joint Gaskets and Grooves for Steel Pipe Flanges
ASME B16.21-1992	Nonmetallic Flat Gaskets for Pipe Flanges
ASME B16.25-1992	Buttwelding Ends
ANSI/ASME B18.2.1-1981 (R1992)	Square and Hex Bolts and Screws — Inch Series
ANSI B18.2.2-1987 (R1993)	Square and Hex Nuts
ASME B31.3-1993	Chemical Plant and Petroleum Refinery Piping
ASME B36.10M-1985 (R1994)	Welded and Seamless Wrought Steel Pipe

**ASME Boiler and Pressure Vessel Code**

Section I	Power Boilers
Section III	Rules for Construction of Nuclear Power Plant Components Division 1
Section VIII	Pressure Vessels — Divisions 1 and 2
Section IX	Welding Brazing Qualifications

**ASTM Publications**

ASTM A 105-95	Carbon Steel Forgings
ASTM A 106-94a	Seamless Carbon Steel Pipe
ASTM A 182-94c	Alloy Steel Forged or Rolled Parts
ASTM A 193-94c	Alloy Steel Bolting
ASTM A 194-94a	Carbon and Alloy Steel Nuts
ASTM A 203-93	Nickel Alloy Steel Plates
ASTM A 207-74a	Carbon-Moly Steel Plates
ASTM A 216-93	Carbon Steel Castings
ASTM A 217-93	Alloy Steel Castings
ASTM A 240-94b	Stainless Steel Plate
ASTM A 275-95	Magnetic Particle Examination of Steel Forgings
ASTM A 302-93	Pressure Vessel Plates, Carbon Steel, Manganese-Molybdenum and Manganese-Molybdenum-Nickel
ASTM A 307-94	Carbon Steel Bolting
ASTM A 312-94b	Stainless Steel Pipe, Seamless or Welded
ASTM A 320-94a	Low-Temperature Alloy Bolting
ASTM A 335-94	Seamless Ferritic Alloy Steel Pipe
ASTM A 350-95	Low-Temperature Alloy Steel Forged or Rolled Parts
ASTM A 351-94	Stainless Steel Castings
ASTM A 352-93	Low-Temperature Carbon and Alloy Steel Castings
ASTM A 354-95	Q & T Alloy Bolting
ASTM A 358-94	Electric Fusion-Welded Stainless Steel Pipe
ASTM A 369-92	Ferritic Alloy Forged or Bored Pipe
ASTM A 387-84	Alloy Steel Plates
ASTM A 388-95	Ultrasonic Examination of Heavy Steel Forgings
ASTM A 430-91	Stainless Steel Forged or Bored Pipe
ASTM A 453-94	Alloy Steel Bolting
ASTM A 479-95	Alloy Steel Bars and Shapes
ASTM A 488-94	Qualification of Procedures for Welding Castings
ASTM A 494-94	Nickel and Nickel Alloy Castings
ASTM A 515-92	Carbon Steel Plates, High Temperature
ASTM A 516-90	Carbon Steel Plates, Low Temperature
ASTM A 537-91	Carbon-Manganese-Silicon Steel Plates
ASTM A 540-93	Alloy Steel Bolting, Special
ASTM A 609-91	Longitudinal-Beam Ultrasonic Inspection for Carbon and Low-Alloy Steel Castings
ASTM A 617-94	Electric-Fusion Welded Steel Pipe
ASTM A 672-94	Electric-Fusion Welded Steel Pipe
ASTM A 675-90a	Carbon Steel Bars
ASTM A 691-93	Carbon & Alloy Steel Pipe — Electric-Fusion Welded
ASTM A 696-90a	Carbon Steel Bars

VALVES — FLANGED  
THREADED, AND WELDING END

ASME B16.34-1996

ASTM A 739-90a	Alloy Steel Bars
ASTM A 789-94	Seamless and Welded Ferritic/Austenitic Stainless Steel Tubing for General Service
ASTM A 790-94	Seamless and Welded Ferritic/Austenitic Stainless Steel Pipe
ASTM B 424-93	Nickel-Iron-Chromium-Molybdenum-Copper Alloy Plate Sheet and Strip
ASTM B 425-93	Nickel-Iron-Chromium-Molybdenum-Copper Alloy Rod and Bar
ASTM B 434-89	Nickel-Molybdenum-Copper Iron Plate, Sheet and Strip
ASTM B 435-94	Nickel-Chromium-Molybdenum-Iron Alloy Plate, Sheet and Strip
ASTM B 443-93	Nickel-Chromium-Molybdenum-Columbium Alloy Plate, Sheet and Strip
ASTM B 446-93	Nickel-Chromium-Molybdenum-Columbium Alloy Rod and Bar
ASTM B 462-91	Chromium-Nickel-Iron-Molybdenum-Copper Columbium Forgings
ASTM B 463-93	Chromium-Nickel-Iron-Molybdenum-Copper Columbium Plate, Sheet and Strip
ASTM B 473-91	Chromium-Nickel-Iron-Molybdenum-Copper Columbium Bar
ASTM B 511-93	Nickel-Iron-Chromium-Silicon Alloy Bars and Shapes
ASTM B 536-94	Nickel-Iron-Chromium-Silicon Alloy Plate, Sheet and Strip
ASTM B 564-94a	Nickel Alloy Forgings
ASTM B 572-94	Nickel-Chromium-Molybdenum-Iron Alloy Rod
ASTM B 573-89	Nickel-Molybdenum-Chromium-Iron Alloy Rod
ASTM B 574-94	Low-Carbon Nickel-Molybdenum-Chromium Alloy Rod
ASTM B 575-94	Low-Carbon Nickel-Molybdenum-Chromium Alloy Plate, Sheet and Strip
ASTM B 581-93	Nickel-Chromium-Iron-Molybdenum-Copper Alloy Rod
ASTM B 582-92	Nickel-Chromium-Iron-Molybdenum-Copper Alloy Plate, Sheet and Strip
ASTM B 599-92	Nickel-Iron-Chromium-Molybdenum-Columbium Alloy Plate Sheet and Strip
ASTM B 620-93	Nickel-Iron-Chromium-Molybdenum-Alloy Plate, Sheet and Strip
ASTM B 621-89	Nickel-Iron-Chromium-Molybdenum-Alloy Rod
ASTM B 622-94b	Seamless Nickel and Nickel-Cobalt Alloy Pipe and Tube
ASTM B 625-93a	Nickel-Iron-Chromium-Molybdenum-Copper-Low-Carbon Alloy Plate, Sheet and Strip
ASTM B 649-89	Nickel-Iron-Chromium-Molybdenum-Copper Low-Carbon Alloy Bar and Wire
ASTM B 672-85	Nickel-Iron-Chromium-Molybdenum-Columbium Alloy Bar and Wire
ASTM E 94-93	Radiographic Test
ASTM E 709-94	Standard Recommended Practice for Magnetic Particle Examination
ASTM E 142-92	Controlling Quality of Radiographic Testing
ASTM E 165-95	Liquid Penetrant Inspection Method
ASTM E 186 (1967-1993)	Reference Radiographs for Heavy-Walled (2 to 4½ in.) Steel Castings

ASME B16.34-1996

- |                        |   |
|------------------------|---|
| ASTM E 280-(1968-1993) | Reference Radiographs for Heavy-Walled (4½ to 12 in.)<br>Steel Castings       |
| ASTM E 446 (1972-1993) | Standard Reference Radiographs for Steel Castings up to 2<br>in. in Thickness |

**MSS Publications**

- |                    |   |
|--------------------|---|
| SP 9-1992          | Spot-Facing for Bronze, Iron, and Steel Flanges                       |
| SP 25-1993         | Standard Marking Systems for Valves, Fittings, Flanges,<br>and Unions |
| SP 45-1992         | Bypass and Drain Connection Standard                                  |
| SP 61-1992         | Hydrostatic Testing of Steel Valves                                   |
| SP 55-1985 (R1990) | Quality Standard for Steel Castings                                   |

**API Publications**

- |              |                           |
|--------------|---------------------------|
| API-598-1990 | Valve Inspection and Test |
|--------------|---------------------------|

**ISO Publications**

- |               |                 |
|---------------|-----------------|
| ISO 9000-1994 | Quality Systems |
|---------------|-----------------|